

Design Consideration of Gearbox for Mazda Jeep

AUNG KO LATT¹, MYO ZAW², SAN YIN HTWE³, THAE SU TIN⁴

^{1,2,3,4} Department of Mechanical Engineering, Mandalay Technological University, Myanmar

Abstract -- The gearbox is one of the most important parts of the power train. This paper emphasis the design and modification of gearbox for four-wheel drive. In the X-2000 (XVA 44 L (1/4) TON CROSS COUNTRY VEHICLE 4 x 4) engine uses the four forward speed gears and one reverse gear. Gears are designed with helical and spur. Gears and shafts are designed with AISI 5160 OQT 400 (SCM21H) heat treated steel. The gears are designed to transmit power and satisfy the dynamic check. The shafts are designed by using ASME code equation. The bearings are also selected based on required design life and basic dynamic load rating. Petrol engines are started use on 20th September 1891 in America. They are widely used in the world till now. In design of manual transmission gearbox, the main components of gearbox housing, shafts and gears can be obtained locally. This paper will support for the development of manufacturing of Mazda Jeep in the Myanmar.

Indexed Terms— bearings, dynamic check, helical, power train, spur

I. INTRODUCTION

Automotive transmission is an important part of the vehicle for running. In the past, human and animals' energies and were used to make a movement. It is caused by wasting our energies. There are not enough using wheels and engines to solve this problem. There must be satisfied with a gear box that connects vehicle engine and wheel with suitable gear ratio and performs to get the rates of vehicle's driving wheel. The gear box of an automobile can be controlled many emergency cases that does not focus on vehicle movements by changing speed and torque of the engine. Although the average engine is driving as much as it can, the movement of the vehicle cannot be if the gear box does not transmit with the engine and the wheels. The gear box consists of different size wheels which may be engaged as required. In automobile, there are two types of transmission, namely manual and automatic transmission. So many cars in various models and locations are still use manual transmission type. Drivers have to shift-lever to the gears. Drivers feel

easy drive in automatic transmission. A typical automobile is powered by a four stroke four-cylinder engine developing an output in the range of 30 to 60 kW at a speed of about 4500 rpm. Four stroke gasoline engines were also used for buses and trucks. They were generally 4000 cc, six-cylinder engines with maximum brake power of about 90 kW. However, in this application gasoline engines have been practically replaced by diesel engines. Automotive transmission gear trains may be used obtain different speeds of an automobile. A simple sliding gear box makes use of a compound gear train and is engaged by sliding the gears on the drive shaft to mesh with the gears on a lay shaft. A differential of an automobile permits the two wheels of a vehicle to rotate at the same speed when driving in straight while allowing the wheels to rotate at different speeds when taking a turn. Thus, a differential gear is a device which adds or subtracts angular displacements [1].

Three types of transmissions are as below.

- (1) Manual transmission
 - (i) Sequential
 - (ii) Non-Synchronous
- (2) Automatic transmission
 - (i) Manumatic
- (3) Semi-automatic transmission
 - (i) Electro hydraulic
 - (ii) Dual clutch
 - (iii) Sexomat
 - (iv) Zero shifts



Fig.1 Manual Transmission Gearbox [2]



Fig.3 Synchronizer Rings [2]

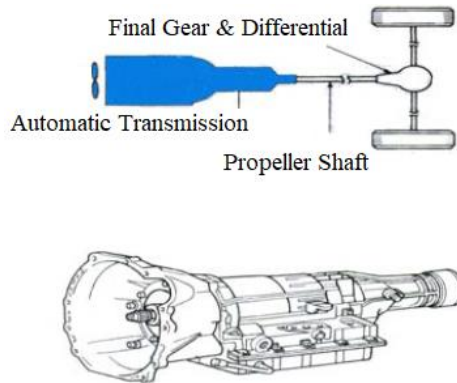

Fig.2 Automatic Transmission Gearbox [4]

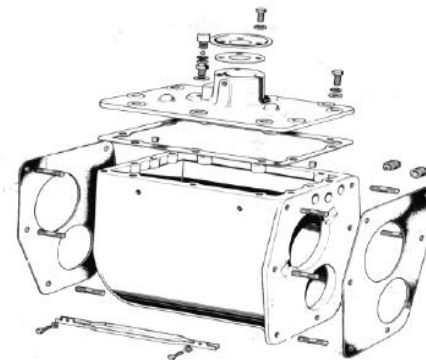

Fig.4 Gearbox Casing [3]

Manual transmissions often feature a driver-operated clutch and a movable gear stick. Most automobile manual transmissions allow the driver to select any forward gear ratio at any time. Some transmissions do not allow the driver to arbitrarily select a gear. Instead, the driver may only ever select the next lowest or next highest gear ratio. Manual transmissions are characterized by gear ratios that are selectable by locking selected gear pairs to the output shaft inside the transmission. Contemporary automobile manual transmissions typically use four to six forward gears and one reverse gear [1].

Main parts and their operation of manual transmission are gears, shafts, mounting the gear onto the shaft, gearbox housing, lubrication, main clutch and synchromesh [2].

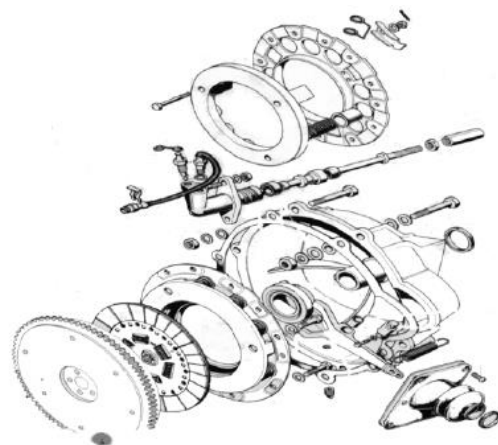

Fig.5 Clutch Controlling System [3]

II. DESIGN CONSIDERATION FOR THE GEARBOX

Specification data for Mazda jeep engine are shown in TABLE I.

Table I: Specification Data [3]

Maximum Speed	120 km/hr
Engine	VA Gasoline, Four Stroke, Four Cylinder, Inline, Overhead Valve, Water Cooled
Maximum Speed	120 km/hr
Piston displacement	1985 cc
Compression ratio	7.0:1
Brake Horse Power	80 hp at 4600 rpm
Maximum Torque	152 Nm at 2000 rpm
Clutch	Single dry plate (hydraulic)

In this type of gearbox, all shafts are parallel. So, the choice is helical gears and spur gears. The design consideration and calculation of transmission are mostly dependent upon the maximum torque of the input speed from the engine. In the X-2000 engine, the gearbox that components are housing, shafts, bearings, gears, synchronizing devices and shifting mechanisms. Before designing gears, it needs to know the relationship between the power available from the engine and the power requirement that arising from the driving resistance.

In gear design, selected material is AISI 5160 OQT 400 which has Brinell hardness 627, yield stress 1750 MPa and ultimate tensile stress 2220 MPa. Helical gear is used for this design. G1 and G2 are constant mesh for any gear drive. The modulus of elasticity is 207Gpa. Profile angle is selected 20° stub involute. To calculate the gear design, require gear ratios are shown in TABLE II. Gear ratios for transmission are first speed gear, second speed gear, third speed gear, fourth speed gear and reverse gear. The gear ratios for transfer case are 4H, 4L and 2H.

Table II: Gear Ratio for The Transmission [3]

Gear Pair	Gear Ratio
Constant Mesh	1.3636
1st	3.9859
2nd	2.3684
3rd	1.47274
4th	1
Reverse	5.3146

Table III: Gear Ratio for The Transfer [3]

Gear Pair	Gear Ratio
4H	1
4L	2.2986
2L	1

XVA-44 is equipped with a four-speed manual transmission, the second, third and top gears are synchromesh type and of the selective sliding mesh type on the low and reverse gear. The transfer case which provides two gear ratios in four-wheel drive and a two-wheel drive is equipped at the rear of the transmission [3].

A. Force in Gear Teeth

To understand the method of computing stresses in gear teeth, it is helpful to consider the way power is transmitted by a gear system.

$$\text{Torque} = \frac{\text{Power}}{\text{Rotational Speed}} \tag{1}$$

The pitch line velocity is derived from the basic relationship, $v = R\omega$, for a point moving in a circle.

$$V = \frac{\pi D_p N_p}{60} \tag{2}$$

where,

D_p = the pinion diameter (m)

V = the pitch line velocity (m/s)

N_p = the rotational speed of the pinion (rpm)

B. Transmitted force

The transmitted force acts tangential to the pitch surface of the gear, actually transmits torque and power from the driver to the driven gear and acts in a direction perpendicular to the axis of the shaft carrying the gear.

$$F_t = \frac{M_t}{\left(\frac{D_p}{z}\right)} \quad (3)$$

C. Radial force

The radial force acts towards the center of the gear radially. The radial force can be computed from the known F_t by using the triangle relation evident.

$$F_r = F_t \tan \phi \quad (4)$$

where, ϕ = the pressure angle of the tooth form

For helical gear, the normal force (F_n) can be computed from the known F_t by using the right triangle relation evident.

$$F_n = \frac{F_t}{\cos \phi_n \cos \phi} \quad (5)$$

where, ϕ_n = the normal pressure angle of the tooth form

Ψ = the helix angle of the tooth form

D. Axial force

The axial force directed parallel to the axis of the shaft carrying the gear and is also called thrust force.

$$F_a = F_t \tan \Psi \quad (6)$$

E. Force in Gear Teeth

The stress analysis of gear teeth is facilitated by considering the orthogonal force components, F_t and F_r . The tangential force, F_t , produces a bending moment on the gear tooth. In the design of a gear for strength, the pitch diameter is either known or unknown. If the pitch diameter is known, the following form of the Lewis equation may be used.

$$\left(\frac{1}{m^2 y}\right)_{all} = \frac{S_{all} k \pi^2}{F_t} \cos \phi \quad (7)$$

where, y = Lewis form factor

For ordinary design condition, the face width for helical gear is six times the circular pitch. $B = kpc$, where $k \leq 6$ for helical gear. So, in this Lewis' equation, $k = 6$ for helical gear, upper limit. If the pitch diameter is unknown, the following form of the Lewis' equation may be used.

$$S_{ind} = \frac{2M_t}{k_y \pi^2 n m^3 \cos \phi} \quad (8)$$

where, S_{ind} = actual induced stress, (N/M²)

M_t = torque in weaker gear (N-m)

n = number of teeth on weaker gear

F. Allowable stress

The allowable stress for gear tooth design depends on the selected material and pitch line velocity (v). For helical gear, the allowable stress for all pitch line velocity is calculated by

$$S_{all} = S_0 \times \frac{5.6}{5.6 + \sqrt{v}} \quad (9)$$

where, S_0 = the endurance strength for released loading

G. Endurance tooth load

The endurance load (F_0) is based on the Lewis equation without a velocity factor. The endurance load is calculated by the following equation.

$$F_0 = S_0 B \pi y m \cos \phi \quad (10)$$

The limited endurance load must be equal to or greater than dynamic load (F_d).

H. Wear tooth load

To insure the durability of a gear pair, the tooth profiles must not have excessive contact stress as determined by the wear load F_w .

$$F_w = \frac{D_p B K_w Q}{\cos^2 \phi} \quad (11)$$

where, D_p = pitch diameter of smaller pinion (m)

D_g = pitch diameter of larger gear (m)

K_w = load stress factor for fatigue (N/m²)

N_p = number of teeth on pinion

N_g = number of teeth on gear

Q = ratio factor

Ratio factor is calculated by

$$Q = \frac{2 \times n_g}{n_p + n_g} = \frac{2 \times D_g}{D_p + D_g} \quad (12)$$

Load stress factor is computed by the following equation.

For helical gear,

$$K_w = \frac{S_{es}^2 \sin \phi_n \left[\frac{1}{E_p} + \frac{1}{E_g} \right]}{1.4} \quad (13)$$

$$\tan \phi_n = \tan \phi \cos \psi \quad (14)$$

where,

S_{es} = Surface endurance limit of a gear pair (MPa)

E_p = Modulus of elasticity of pinion material (MPa)

E_g = Modulus of elasticity of gear material (MPa)

ϕ = Pressure angle

ψ = Helix angle

The surface endurance limit may be estimated from this equation

$$S_{es} = (2.75 \times \text{BHN}) - 70 \quad (15)$$

where, BHN = average Brinell hardness number of gears

The wear load F_w is an allowable load and must be equal to or greater than the dynamic load F_d .

I. Dynamic tooth load

For helical gear, the dynamic analysis is proposed by Buckingham.

$$F_d = \frac{21 \times v (BC \cos^2 \phi + F_t) \cos \phi}{21 \times v + \sqrt{(BC \cos^2 \phi + F_t)}} + F_t \quad (16)$$

where, C = Dynamic factor (N/m) [5]

III. DESIGN CONSIDERATION FOR SHAFTS

The shafts must be designed against failure by overload as well as fatigue. In a rear wheel drive transmission, the input and output shaft lie along the same line, and may in fact be combined into a single shaft within the transmission. Front wheel and rear wheel drive transmissions operate similarly. When the transmission is in neutral, and the clutch is disengaged, the input shaft, clutch disk and countershaft can continue to rotate under their own inertia. In this state, the engine, the input shaft and clutch, and the output shaft all rotate independently. In transmission, input drive shaft, counter shaft, main shaft, front output shaft, rear output shaft and idler shaft are used as the rotation element to transmit the power of engine to drive axles. AISI 5160 OQT 400 is used for the shafts. The ultimate strength 2220 MPa and yield strength 1790 MPa and modulus of elasticity is 207 GPa. Shaft design calculation is based on maximum tangential load at first speed range. Therefore, all shafts design is considered in first speed position.

Shafting is usually subjected to torsion, bending and axial loads. For tensional loads, the tensional stress, τ_{xy} is

$$\tau_{xy} = \frac{M_t r}{J} = \frac{16 M_t}{\pi d^3} \text{ for solid shaft} \quad (17)$$

$$\tau_{xy} = \frac{16 M_t d_o}{\pi (d_o^4 - d_i^4)} \text{ for hollow shaft} \quad (18)$$

For bending loads, the bending stress S_b (tension, compression) is

$$S_b = \frac{M_b r}{J} = \frac{32 M_b}{\pi d^3} \text{ for solid shaft} \quad (19)$$

$$S_b = \frac{32 M_b d_o}{\pi (d_o^4 - d_i^4)} \text{ for hollow shaft} \quad (20)$$

For axial loads, the tensile stress S_a is

$$S_a = \frac{4 F_0}{\pi d^2} \text{ for solid shaft} \quad (21)$$

$$S_a = \frac{4 F_0}{\pi (d_o^2 - d_i^2)} \text{ for hollow shaft} \quad (22)$$

The ASME code equation for a solid shaft combines torsion; bending and axial loads by applying the maximum shear equation, modified by introducing

shock, fatigue and column factors as follows. For a solid shaft having little or no axial loading, the code equation reduces

$$d^3 = \frac{16}{\pi S_s} \sqrt{(K_b M_b)^2 + (K_t M_t)^2} \quad (23)$$

For a solid shaft having axial loading, the code equation reduces to

$$d^3 = \frac{16}{\pi S_s} \sqrt{(K_b M_b + \frac{\alpha F_a d}{8})^2 + (K_t M_t)^2} \quad (24)$$

For a hollow shaft having axial loading, the code equation reduces to

$$d_o^3 = \frac{16}{\pi S_s (1-K^4)} \sqrt{(K_b M_b + \frac{\alpha F_a d_o (1+K^2)}{8})^2 + (K_t M_t)^2} \quad (25)$$

where, S_s = allowable stress (N/m²)

M_t = torsional moment (N-m)

M_b = bending moment (N-m)

d_o = shaft outside diameter (m)

d_i = shaft inside diameter (m)

F_a = axial load (N)

K_b = combined shock and fatigue factor applied to moment

K_t = combined shock and fatigue factor applied to torsional moment.

K_b and K_t for the shaft design calculation are shown in TABLE IV.

$$K = \frac{d_i}{d_o} \quad (26)$$

For a compression load, column action factor (α) may be computed by

$$\alpha = \frac{1}{1 - 0.0044 \left(\frac{L}{K}\right)} \text{ for } \left(\frac{L}{K}\right) < 115 \quad (27)$$

$$\alpha = \frac{S_y}{\pi^2 n E} \left(\frac{L}{K}\right)^2 \text{ for } \left(\frac{L}{K}\right) > 115 \quad (28)$$

$n = 1.0$ for hinged ends

$n = 2.25$ for fixed ends

$n = 1.6$ for ends partly restrained, as in bearings

$$k = \text{radius of gyration} = \sqrt{\frac{I}{A}} \text{ (m)}$$

Table IV: K_b and K_t For Shaft Design Calculation

For stationary shaft	K_b	K_t
Load gradually applied	1	1
Load suddenly applied	1.5 to 2.0	1.5 to 2.0
For rotating shaft	K_b	K_t
Load gradually applied	1.5	1
Load suddenly applied (minor shock)	1.5 to 2.0	1.0 to 1.5
Load suddenly applied (minor shock)	2.0 to 3.0	1.5 to 3.0

ASME code to state for commercial steel shafting.

S_s (allowable) = 8000 psi for shaft without keyway (55 MN/m²)

S_s (allowable) = 6000 psi for shaft with keyway (40 MN/m²)

ASME code states for steel purchased order.

Definite specifications S_s (allowable) = 30% of the elastic limit but not over 18% of the ultimate strength in tension for shafts without keyways. These values are to be reduced by 25% if keys are present. Standard size of shafting should be used where possible. These sizes vary according to material specification and supplier. Typical sizes for solid shafts are

- (i) up to 25 mm in 0.5 mm increments
- (ii) 25 to 100 mm in 2 mm increments
- (iii) 100 to 200 mm in 5 mm increments

For belt drive, the torque is found from the equation

$$M_t = (T_1 - T_2) \times R \quad (29)$$

where, T_1 = tight side of belt on pulley (N)

T_2 = loose side of belt on pulley (N)

R = radius of pulley (m)

For a gear drive, the torque is found from the equation

$$M_t = F_t \times R \tag{30}$$

where,

F_t = tangential force at the pitch radius (N)

R = pitch radius (m) [5]

IV. DESIGN CONSIDERATION FOR THE BEARINGS

Bearings are designed by using gears and shafts data. A bearing is a machine part whose function is to support a moving element and to guide or confine its motion, while preventing motion in the direction of applied load. They take up the radial and axial loads imposed on the shaft or axle they carry and transmit these to the casing or machine frame.

A. Loads and factor on bearings

The equivalent bearing load,

$$P = XV F_r + Y F_a \tag{31}$$

where, X = radial factor

V = rotation factor

Y = thrust factor

F_r = the radial load

F_a = the thrust load

Pure radial load, F_a = 0, X = 1 → P = V F_r

Single row bearing,

Thrust force does not influence the equivalent load.

Table V: Results of Gear Design

Type of speed	No. of Teeth	Dia (mm)	m (mm)	ψ (°)	b (mm)	Speed (rpm)	Center distance (mm)
Drive Speed	22	44	2	30	38	20000	52
	30	60	2	30	38	1467	52
First Speed	38	78	2	0	38	501.8	52
	13	27	2	0	38	1467	52
Second Speed	33	66	2	30	38	844.6	52
	19	38	2	30	38	1467	52
Third Speed	27	54	2	30	38	1358	52
	25	50	2	30	38	1467	52
Reverse Speed	15	36	2.5	0	47	954	63
	20	50	2.5	0	47	1467	63
Low Speed	31	78	2.5	30	47	1467	105
	47	132	2.5	30	47	968	105
Top Speed	31	78	2.5	30	47	2000	105
	47	132	2.5	30	47	1319	105

Table VI: Results of Shaft Design

Type of Shaft	Material	Dia; (mm)	Length(mm)
Input	5160 OQT 400	25	217
Main	5160 OQT 400	25	220
Counter	5160 OQT 400	30	253
Reverse	5160 OQT 400	20	98
Rear Output	5160 OQT 400	35	165
Front Output	5160 OQT 400	35	140
Idler	5160 OQT 400	35	155

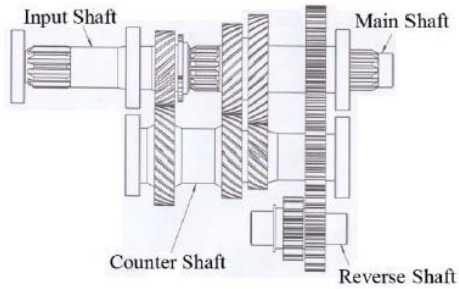

Fig.6 Gear Mesh for Transmission

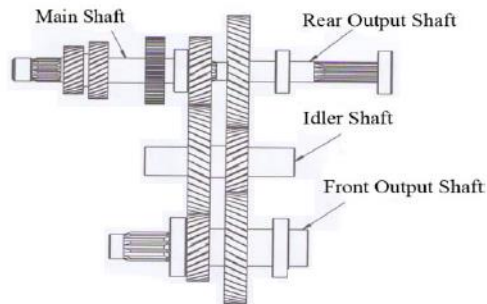

Fig.7 Gear Mesh for Transfer Case

V. CONCLUSION

In this paper, gear design and shaft design are considered, and the bearings are selected. Generally, two types of gears are used in transmission such as spur (1st and reverse gear) and helical gear. After knowing the gear ratio for the manual gearbox, the number of teeth of gears and gear parameter are specified. And then, the gear design is carried out. The required design, all gear teeth of transmission gearbox must have sufficient strength and they will not fail under static loading or dynamic loading during normal operation. Therefore, the wear characteristic and the endurance limit of the gear material are considered in this gear design. The wear tooth load and static tooth load of all gear pairs are greater than the dynamic tooth load of the gear. Therefore, the gear design is satisfactory. In the shaft design, the shaft diameters for variety of speeds calculated by using the ASME code equation. The bearings for this gearbox are selected based on the diameter of shafts and basic dynamic load capacity. The design bearing life of machine is assumed 2500 working hours from recommended bearing catalogue.

REFERENCES

- [1] Gorla, Carlo, Franco Concli, Karsten Stahl, Bernd-Robert Höhn, Michaelis Klaus, Hansjörg Schultheiß, and Johann-Paul Stemplinger. "CFD simulations of splash losses of a gearbox." *Advances in Tribology*, 2012.
- [2] Patel, Mitesh, A. V. Patil, Mitesh Patel, and A. V. Patil. "Stress and Design Analysis of Triple Reduction Gearbox Casing." *International Journal* 2: 2011.
- [3] Guan, Yuan H., Teik C. Lim, and W. Steve Shepard. "Experimental study on active vibration control of a gearbox system." *Journal of Sound and Vibration*, 2005.
- [4] Sellgren, Ulf, and M. Akerblom. "A model-based design study of gearbox induced noise." In *DS 32: Proceedings of DESIGN 2004, the 8th International Design Conference*, Dubrovnik, Croatia, 2004.
- [5] Dodge Raider: "Manual Five Speed Automobile Forum". Hal Gurgenci: "Gearbox Design" August, 2002.
- [6] KASALA: "Mazda XVA 44IL (1/4) Ton Cross Country Vehicle 4x4 (L.H.D)" Heavy Industries Corporation in Cooperation with Mazda Motor Corporation, Pyay, 2000.
- [7] Central Machine Tool Institute, 1999. *Machine Tool Design Hand Book*, Tata McGraw-Hill Publishing Company, 1999.
- [8] Mehta N.K, *Machine Tool Design and Numerical Control*, Tata McGraw-Hill Publishing Company, 1999.
- [9] Gopal Chandra Sen and Amitabha Bhattcharyya, *Principles of Machine Tools*, Jadavpur University, 1998.