

A Study of Temperature Distribution in CI Engine Exhaust Valve

SAN YIN HTWE¹, MYO ZAW², AUNG KO LATT³, KHIN KHIN KHAING⁴

^{1,2,3,4} Department of Mechanical Engineering, Mandalay Technological University, Myanmar

Abstract- Exhaust valve of a compression ignition engine is one of the most crucial parts in the engine head. It is the main cause of most problems like pre ignition etc. Both the inlet and exhaust valves are subjected to high temperatures during the power stroke, therefore, it is necessary to take care about the materials of the valves such that it should withstand those higher temperatures. Design of the valve depends on so many different parameters like fluid dynamics of exhaust gas, behavior of material at high temperature, oxidization characteristics of valve material and exhausts gas, fatigue strength of valve material, coolant flow and the shape of the exhaust port etc. The most important factor affecting the performance of a valve is its operating temperature i.e. temperature at the inlet valve is less compared to exhaust valve. In first stage, 3D model of the exhaust valve is modeled, and the analysis is done using COMSOL 4.3b software. In this paper, the design of engine exhaust valve and its temperature distribution are discussed. The above process of thermal analysis is carried out with two different materials i.e. 21-4N super alloy and Nimonic 80A and finally the best material is suggested for the valve based on its strength and thermal properties.

Indexed Terms — Compression ignition, COMSOL, Inlet and exhaust valve, Operating temperature.

I. INTRODUCTION

Internal combustion engine is being used for various applications such as automobile industry, construction machinery, trucks of coal mine, industrial applications etc. We know that IC engine is power generating system that is the reason because of which its applications are rapidly increasing. An IC engine consists of two types of valves- inlet valve and exhaust valve. Diesel engine has of number of important components, which perform various functions and are subjected to different stresses, forces and thermal loadings. Out of these many important components of engine inlet and exhaust valves are most important and there operation should be particularly taken care. The functioning of valves is well studied using valve

timing diagram. The function of inlet valve is to provide the path for air to flow into the combustion chamber. Function of exhaust valve is to remove the combusted gases out of the cylinder i.e. when the fuel and air mixture has been ignited in the cylinder, the spent gases are sent out of the engine through this valve. So this exhaust gases carry high temperatures with them. Due to the exposure to high temperature gases after combustion, exhaust valve design is of a crucial interest. During the power stroke both the inlet and exhaust valves are subjected to high temperatures of 1930°C to 2200°C, therefore, it is necessary to take care about the materials of the valves such that it should withstand those higher temperatures [3]. So finally, we can say that valves will be exposed to high thermal stresses. In spite of that, these valves are also exposed to cyclic mechanical stresses during opening and closing of valves which may cause permanent valve failure [5]. The Hardness and yield strength of valve material will be decreasing because of this high thermal stress i.e. temperature and also causes corrosion of exhaust valves [1]. So the exhaust valve should be made with the material which is highly resistant to temperature and stresses. Nowadays engine are designed with multi valves i.e. two inlets and one exhaust or two inlets and two exhaust valves which prevents air pollution and improves engine efficiency [2]. The valve mechanism will control the opening and closing of inlet and exhaust during the engine operation. The most significant factor about the performance of a valve is its operating temperature. The importance of temperature can be appreciated by its effect on the physical properties of the valve material. Most automotive exhaust valves operate in the temperature range of 650°C to 875°C. It is therefore proper care has to be given in selecting the material for the valve operating at high temperatures. Exhaust valves with better material strength can provide significant benefits in cost reduction and also reducing its weight [1]. Opening angle and closing angle of exhaust valve plays important role if we

consider performance and fuel consumption of the engine. Due to this opening and closing of valves should be optimum in order to get maximum power with less fuel consumption. The exhaust valve generally opens 20-40° before bottoming dead center and closes 10-20° after top dead center [4].

II. VALVE OPERATING TEMPERATURES

The most significant factor that will affect the performance of a valve is its operating temperature. Most automotive exhaust valves operate in the temperature range of 650°C to 875°C. It is therefore proper care has to be taken in selecting the material for the valve operating at High thermal stresses (high temperature) and mechanical stresses. Exhaust valves may reach a maximum temperature of 800°C. The valve temperature increases with engine speed, an increase in the compression ratio, lowers the valve temperature and the Valves of large diameter will be hotter than smaller ones.

III. EXHAUST VALVE

Both the inlet and exhaust valves are mounted on the cylinder heads. These are the very crucial parts of the engine. These valves play the vital role in the working of the engine. Inlet valve is used for the inletting the air in to the cylinder which operates by the action of Tappet movement, allows air and fuel mixture into the cylinder. Exhaust valve is used for the removal of burnt exhaust gases of high temperature after combustion to escape out of cylinder. Generally, inlet valves are larger than the exhaust valves, because velocity of charge entering in to the cylinder is less than the velocity of exhaust gases which leaves out of cylinder under high pressure. Because of high pressure of gases coming out of the cylinder, the density of exhaust gases is also comparatively high. Moreover, smaller exhaust valve is also preferred because of the shorter path of heat flow and consequent reduces thermal loading. Valve efficiency depends on many characteristics like Hardness, Face roundness and sliding properties capable to withstand high temperature etc. The pressures and temperatures that are induced using various types of fuels and its combustion characteristics will affect the valves because they will be exposed to different mechanical

and thermal stresses.

There are many type of valves out of which Poppet valve is more advanced valve. This type of valve used in our project is a poppet valve. It is also called as mushroom valve. This valve is typically used to control the timing and quantity of gas or vapor flow into an engine'. The poppet-valve is most commonly used because this will offer reasonable weight, good strength and good heat transfer characteristics. The most popular shape of the poppet-valve is that it has a stem and head for automobile application. The valve stem is placed in a guide hole made centrally in a circular passage in the cylinder head. The positioning of Valves may be vertically or slightly inclined relative to the cylinder axis, matching the desired combustion chamber contour. Poppet valves have different configurations within the engine relative to the cylinders. The poppet valve derives its name from its popping movement up and down. It possesses certain advantages over other types of valve because of which it is heavily used in the automotive engines.

A. Exhaust Valve Material Requirements

The material of exhaust valve should have the following properties if consider operation conditions:

1. To resist tensile loads material should have high strength
2. and hardness.
3. To avoid excessive thermal stresses in the head the
4. coefficient of thermal expansion should be of least value.
5. High hot strength and hardness to combat head cupping
6. and wear of seats.
7. 4. There should be high corrosion resistance.
8. 5. For better heat dissipation material should have high
9. thermal conductivity.
10. 6. Material should have high strength and hardness to resist
11. stem wear.
12. 7. High fatigue and creep resistance.

B. Selection of Valve Material

For this paper, 21-4N super alloy and Nimonic 80A is selected. The most popular materials for exhaust valves are austenitic stainless-steel alloys such as 21-2N and 21-4N. Austenite forms when steel is heated above a certain temperature and austenite formation depends on the type of alloy. The automatizing temperature ranges from 1600° to 1675° F for many steels, which is about the temperature where hot steel goes from red to nearly white. The carbon in the steel essentially dissolves and coexists with the iron in a special state where the crystals have a face-centered cubic structure. By adding other trace metals to the alloy such as nitrogen, nickel and manganese, the austenite can be maintained as the metal cools to create steel that has high strength properties at elevated temperatures. Chromium is added to increase corrosion resistance. The end product is an alloy that may not be as hard at room temperature as martensitic steel, but is much stronger at the high temperatures at which exhaust valves commonly operate.

Nimonic is a registered as special Metal that refers to a family of nickel-based high- temperature low creep super alloys. Nimonic alloys typically consist of more than 50% nickel and 20% chromium with additives such as titanium and aluminum. The main use is in gas turbine components and extremely high performance reciprocating internal combustion engines.

Table 1. Chemical Composition of Super Alloy 21-4n

Element	Content %
Chromium, Cr	21
Manganese, Mn	9
Nickel, Ni	3.88
Carbon , C	0.53
Silicon ,Si	0.25 max

Table 2. Chemical Composition of Nimonic 80a

Element	Content %
Chromium	18-21%
Iron	3%
Titanium	1.8-2.7%
Aluminum	1-1.8%
Silicon	1%

Manganese	1%
Copper	0.2%
Cobalt	0.2%
Carbon	0.1%
Phosphorus	0.045%
Boron	0.008
Nickel	Balance

IV. DESIGN CONSIDERATIONS

The valve shown in Fig.1 is a solid stem poppet valve. Where d_f is valve face diameter, t is the valve head thickness, d_p is valve port diameter, d_s is the stem diameter and α is the seat angle [8].

There are three forces acting on the valve. They are the gas load which is occurred by combustion, the spring force at the collet part and the force due to acceleration which is caused when the reciprocating movement of the valve. Conduction heat transfer is occurred along the valve and convection heat transfer is occurred in the exhaust port by exhaust gas and at the stem side by engine oil. The temperature of the engine oil is assumed as atmosphere temperature, 298 K.

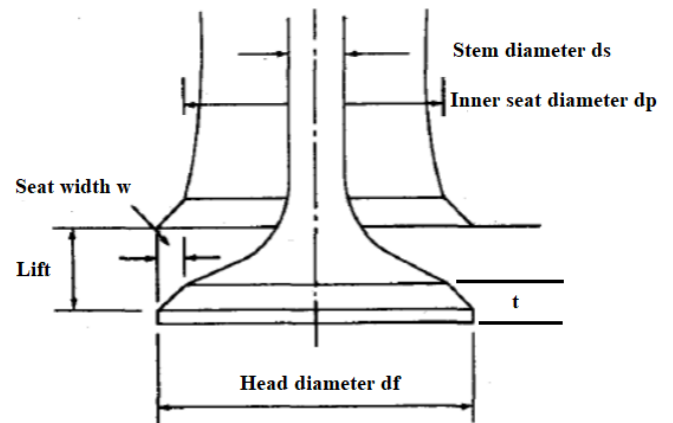

Fig.1 Poppet Valve

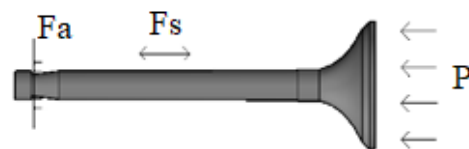

Fig.2 Forces Acting on Valve

Table 3. Properties of Materials

Properties	21-4N	Nimonic 80A
Density (g/cm ³)	7.7	8.19
Ultimate tensile strength (MPa)	882.6	999.7
Tensile yield strength (N/mm ²)	1000	930
Compressive yield strength (N/mm ²)	580	620
Youngs modulus (kN/mm ²)	215	222
Thermal conductivity (W/m ⁰ C)	14.5	11.2
Coefficient of expansion μ (/ ⁰ C)	14.5	12.7

$$t = k_1 d_p \sqrt{\frac{P_2}{\sigma}} \quad (1)$$

$$d_f = d_p + 2[t \times \sin(90 - \alpha_v)] \quad (2)$$

$$d_s = \frac{d_p}{8} + 6.35 \quad (3)$$

$$h = \frac{0.25d_p}{\cos \alpha_v} \quad (4)$$

$$q_{conv} = hA\Delta T \quad (5)$$

$$q_{cond} = kA \frac{\Delta T}{l} \quad (6)$$

$$w = c_1 s_p + c_2 \frac{V_d T_2 (P - P_m)}{P_2 V_2} \quad (7)$$

$$c_1 = 2.28 + 0.308 \times \frac{v_s}{S_p} \quad (8)$$

$$c_2 = 3.24 \times 10^{-3} \quad (9)$$

$$h_c = 3.26B^{-0.2} P_3^{0.8} T_g^{-5.5} W^{0.8} \quad (10)$$

$$h = \frac{Nu k}{l} \quad (11)$$

The temperature distribution along the valve is calculated by using numerical network for two dimensional systems. The assumption is needed that here

is no heat generation. The condition is considered as steady state. Therefore, the energy to a node is equal to the energy from this node. The condition is considered as steady state. The energy equation is expressed as

$$E_{in} - E_{out} - E_g = E_{st} \quad (12)$$

Table 4. Thermophysical Properties Of Engine Oil [7]

Parameter	Value	Unit
μ	486×10 ⁻³	Ns/m ²
ρ	884.	Kg/m ³
v	550×10 ⁻⁶	m/s
Pr	640	-
k	0.14	W/mK
T	298	K
cp	190	J/kg

V. RESULTS AND DISCUSSION

The valve seat diameter is taken as 30 mm as valve seat is fit with the valve port. The valve port diameter is the same as the valve seat diameter. The data of the exhaust valve design is show in the following TABLE 5 and the result of the forces acting on the valve is shown in TABLE 4.

Table 5. Dimension of Exhaust Valve

Part Name	Symbol	Value
Valve stem diameter	d _s	8
Valve lift	h	15
Valve seat diameter	d _p	30
Diameter of valve face	d _f	35
Thickness of valve disc	t	3

Table 6. Forces Acting on The Valve

Parameter	Value	Unit
Stress in valve due to spring force	10.5	MN/mm ²
Spring force, F _s	90.5	N
Gas load, P	935.5	N
Force due to acceleration, F _a	99.5	N
Total load on the exhaust valve, F _e	1125.5	N

The heat transfer coefficient in the exhaust port is 1250 W/m^2K and the heat transfer coefficient of engine oil is 8 W/m^2K which is along the valve stem. The values of the temperature decrease on each nodes which are along the centre of the valve face to the top of the valve stem. The temperature distributes till 299 K when it reaches to the valve stem.

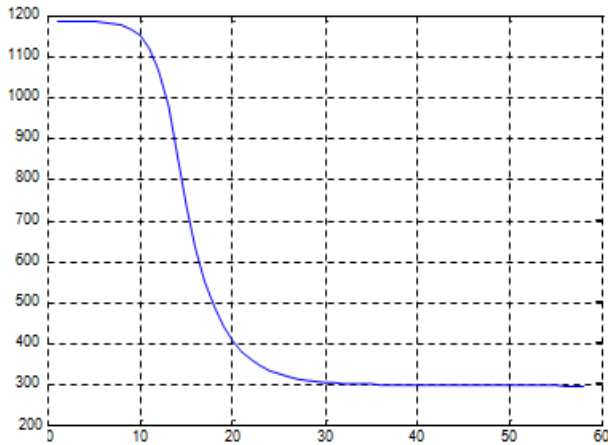

Fig.3 Temperature Distribution along the Center of Valve

The temperature distribution of valve is determined by using the steady state thermal analysis. The finite element analysis for steady state thermal analysis of the exhaust valve is carried out by using COMSOL 4.3b software. Fig.4 to Fig.7 shows the temperature distribution on the valve. According to the simulation result, the temperature of the exhaust valve reduces more in Super Alloy 21-4N than Nimonic 80A.

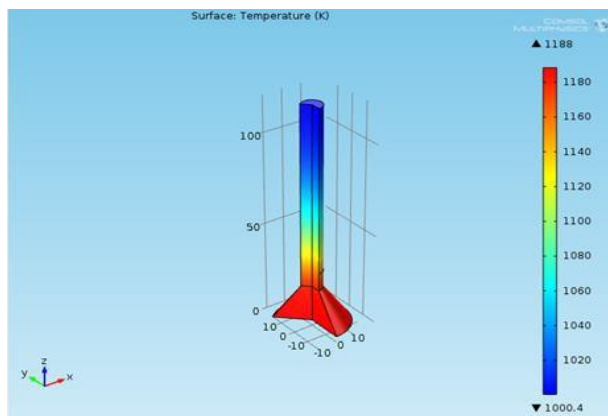

Fig.4 Temperature Distribution on 3D Valve for Super Alloy 21-4N

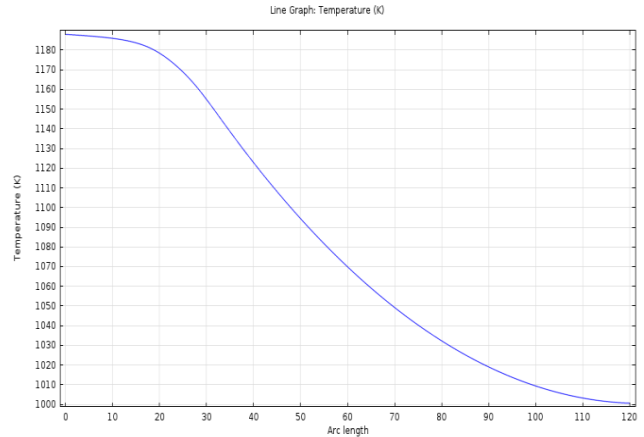

Fig.5 Temperature Distribution on the Valve for Super Alloy 21-4N

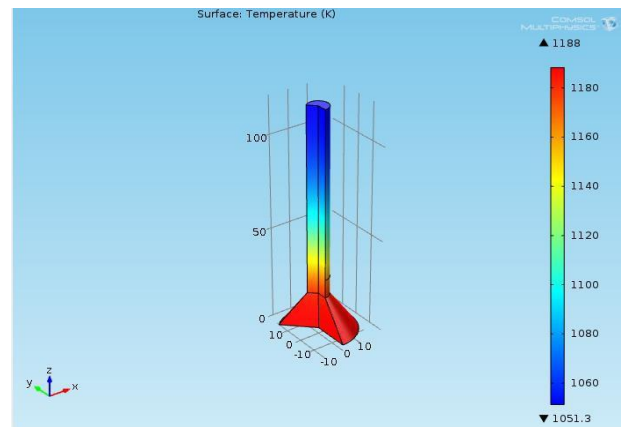

Fig.6 Temperature Distribution on 3D Valve for Nimonic 80A

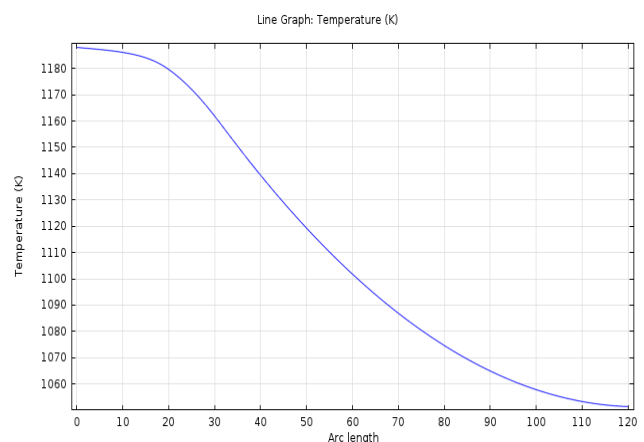

Fig.7 Temperature Distribution on the Valve for Nimonic 80A

VI. CONCLUSION

In this paper, the design and heat transfer is studied on exhaust valve for diesel engine. The fundamental concepts and the design concerning this engine have been studied. From engine specification, the thickness of the valve head and the other dimensions can be calculated. In this paper, the heat transfer on the valve is analyzed by using COMSOL Multiphysics according to the basic theory of heat transfer analysis. The heat transfer coefficients around the valve are calculated. The numerical results of the valve at nodes are compared with theoretical results. The temperature distribution decreases from valve face to tip. According to the simulation result, Super Alloy 21-4N is the best material.

[8] R.J. Khurmi, A Text Book of Machine Design, 2005.

REFERENCES

- [1] Naresh Kr. Raghuvanshi, Ajay Pandey, R. K. Mandloi, Failure Analysis of Internal Combustion Engine Valves, International Journal of Innovative Research in Science, Engineering & Technology, Vol 1, Issue 2, Dec-2012, ISSN 2319-8753.
- [2] B Seshagiri Rao and D Gopi Chandu, international journal of mechanical engineering and robotics research, , Vol. 3, No. 4, October, 2014, ISSN 2278 – 0149.
- [3] Korri pradeep kumar, a. Raveendra, thermal load effect on valve by using conventional and blended fuels, International Journal of Engineering Research-Online, vol.3, Issue.6, 2015, Nov-Dec, ISSN:2321-7758.
- [4] Rohit T. Londhe, J.M. Kshirsagar, Experimental Analysis of Valve and Valve Seats Wear in Gases (CNG) Fuelled Engine, Volume 11, Issue 4 Ver. I (Jul- Aug. 2014), ISSN: 2278-1684, p-ISSN: 2320-3345.
- [5] Naresh Kr. Raghuvanshi, Ajay Pandey, R. K. Mandloi, Failure Analysis of Internal Combustion Engine Valves, A Review, International Journal of Innovative Research in Science, Engineering & Technology, Vol 1, Issue 2, Dec-2012, ISSN 2319-8753.
- [6] Singaiah Gali, T.N. Charyulu, Diesel Engine Exhaust Valve Design, Analysis and Manufacturing Processes, Indian Stream Research Journal, Vol.2, Issue 7, Aug. 2012, ISSN 2230-7850.
- [7] Ramesh K. Shah and Dusan P.Sekulic, Fundamental of Heat Exchanger Design, 2003.