

# Design of Dual Band Y-Shaped Micro strip Patch Antenna

G NAVEEN KUMAR<sup>1</sup>, K MEGHANA DEVI<sup>2</sup>, N KEERTHI<sup>3</sup>, N SRI PRIYA<sup>4</sup>

<sup>1</sup> Associate Professor, Department of ECE, VVIT, Nambur, Guntur, Andhra Pradesh, India

<sup>2,3,4</sup> Student, Department of ECE, VVIT, Nambur, Guntur, Andhra Pradesh, India

**Abstract-** Now-a-days Microstrip Antennas are widely used because of their small size, light weight, low cost, high performance etc. The proposed design is Y-shaped Microstrip Patch Antenna is procured by inserting Y-shaped strip in a circular hole in square patch microstrip antenna. The feeding technique used is microstrip line feeding. The Y-shaped dual band microstrip line feed antenna is mounted on a substrate of thickness 1.6mm with the relative permittivity of 4.4 and arranged above the ground plane. The measured return losses are -15.135dB and -27.608dB at resonant frequencies of 4.0MHz and 5.7MHz. The obtained maximum impedance bandwidths are 438.6MHz and 332.2MHz which is near about 10.965% and 5.82% and radiation patterns are measured. It is applicable for wireless communications.

**Indexed Terms-** patch antenna; Y-shaped; Return loss; wireless communications.

## I. INTRODUCTION

The rapid evolution of wireless communications desires the need of antennas that covering multiple bands with good radiation characteristics. Currently, the government as well as commercial applications such as mobile, radio and other wireless communication [1]-[4]. Microstrip patch antennas consists of three parts they are: 1.patch 2. Substrate 3. Ground plane. Patch and ground are separated by a dielectric material and the material used to build them is same here we use the material PEC (Patch excited cup) [5]-[6].

In this project the attempt has been made to build up the narrow bandwidth of patch antenna on a substrate by inserting a Y-shape in a circle on the rectangular patch. Amend the structure is simulated to verify the return loss gain of the antenna and various intensive

bandwidth enrichment techniques [7]. These techniques based on utilization of thick substrate with low dielectric constant. The usage of thick substrate results in miniature success because when length of a probe feed is increased. The large inductance gets introduced, which results in small amount of bandwidth at resonant frequency [8]-[11]. The design of dual band microstrip patch antenna is proposed and it is designed using CST software [12]. All parameters are amend for designing of such type of antenna. So it can be available for wireless communication system.

## II. DESIGN OF Y-SHAPED MICROSTRIP PATCH ANTENNA

Design dimensions and characterized details of the Y-shaped patch antenna is shown in Figure 1. It has appealing features such as low profile and ease of fabrication when compared with conventional wide-band microstrip antennas. Initially the square patch with the circular hole is designed with the material PEC then Y-shaped strip is inserted enforced in square patch. After completion of patch design substrate must be placed in between ground and patch.

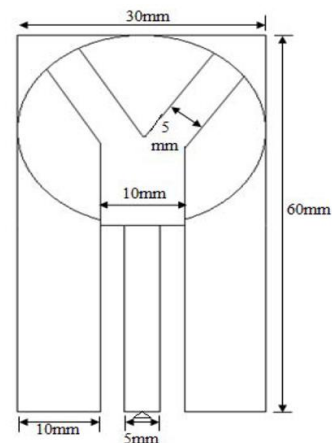

Figure 1: Proposed design of dual band Y-shaped microstrip patch antenna

Here FR4 substrate is chosen because of low cost, subsequently ground is designed. There are different types of feeding techniques in that we chose line feeding technique. In order to give wave guide port first we need to select the feed line of strip then extend to the ground by selecting the pick face to align the positive orientation. The currents of the ground plane on different regions are measured for the effective antenna performance. The dimensions of ground and substrate are shown in table 1.

The fabrication of antenna is done by the technique lithography. It is the printing process in which we can print the designed antenna on a metal substrate.

S. no	Name	Xmin	Xmax	Ymin	Ymax	Zmin	Zmax
1.	Ground	-15	15	-30	-3	-1.6785	-1.6
2.	Substrate	-15	15	-30	30	-1.6	0
3.	Wave guide port	-	-	-	-	2.2204-1.6	0.1+6.4

Table 1: Dimensions of ground and substrate  
In the above table wave guide port Ypos: -30

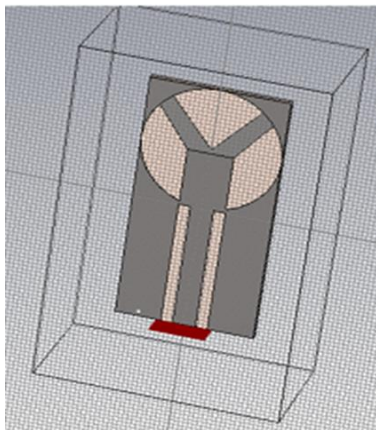

Figure 2: Designed Y-Shaped microstrip patch using CST

### III. RESULTS AND CONCLUSION

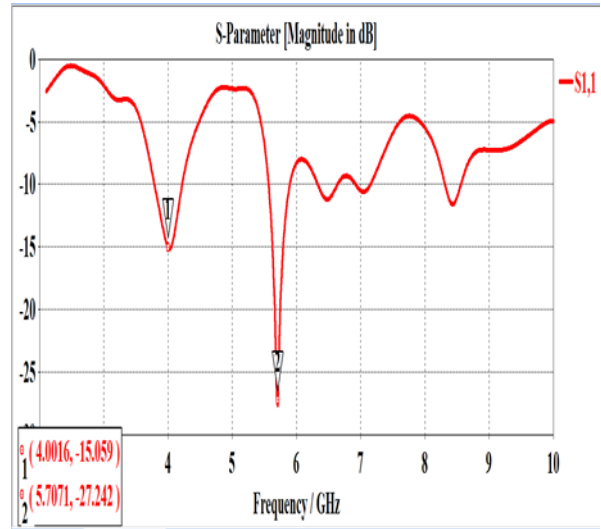

Figure 3: Magnitude (DB) v/s frequency curve for the proposed antenna at dual frequencies (4.0016 GHz, 5.7071 GHz)

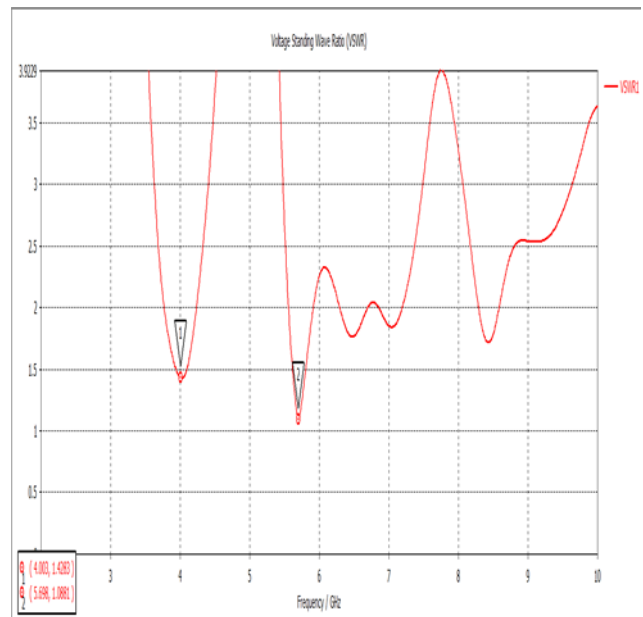

Figure 4: VSWR v/s frequency curve for the Proposed antenna for dual frequencies

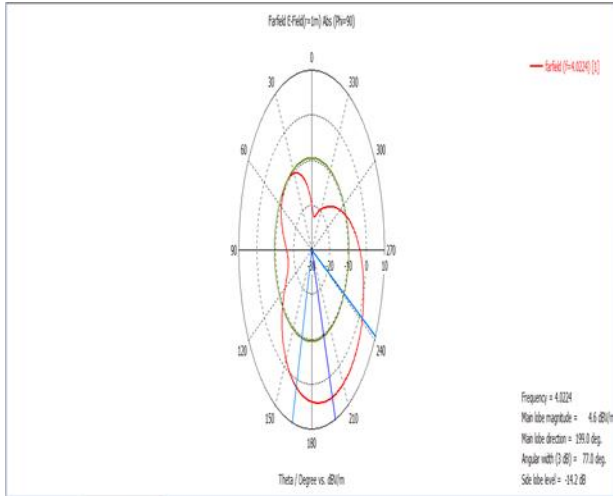

Figure 5: Radiation pattern of proposed antenna at 4.0016 GHz

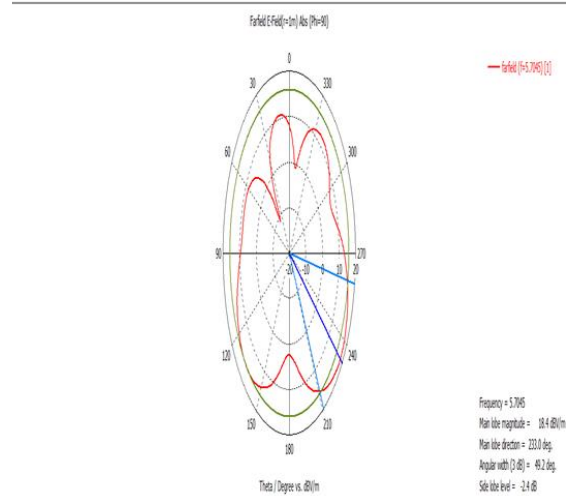

Figure 7: Radiation pattern in 3D of proposed antenna at 5.7071 GHz

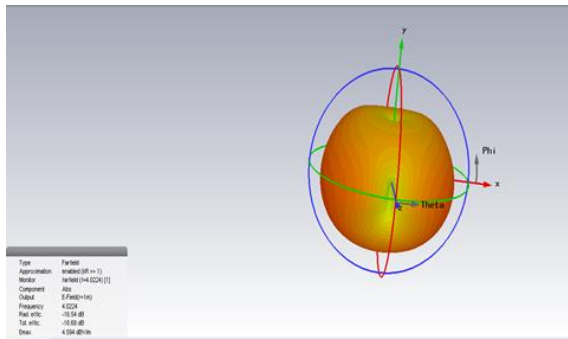

Figure 6: Radiation pattern in 3D of proposed antenna at 4.0016 GHz

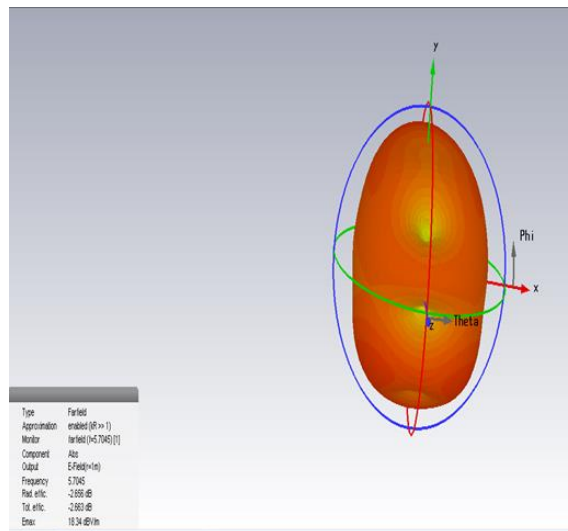

Figure 7: Radiation pattern in 3D of proposed antenna at 5.7071 GHz

The below table 2 shows the results of patch antenna

S.no	Antenna	Resonant Frequency ( GHz)	Return Loss (dB)	Maximum impedance Bandwidth ( MHz)	in (%)
1.	Design of dual band	4.0016	-15.059	438.6	10.965
2.	Y-Shaped	5.7071	-27.24	332.2	5.82

Table 2: Simulated results of Y-Shaped patch Antenna

The antenna design indicate that dual band Y- shaped antenna with impedance bandwidth of 10.965% and 5.82%. The antenna represented the minimum return losses of -15.059 dB and -5.7071 dB with resonant frequencies 4.0016 GHz and 5.7071 GHz. This antenna is well applicable for small electronic devices for its compactness and in wireless communications due to its dual band frequencies and low cost of realization with its elementary layout.

#### IV. FUTURE SCOPE

The future scope is to narrow patch size and improve impedance bandwidth. It can be attained by fragmenting the slots on square patch microstrip line feed antenna.

#### REFERENCES

- [1] M.C. Ezuma, S. Subedi, "Design of a Compact Antenna for Multi-band Wireless Applications" IEEE [ICON-2015]
- [2] M. Ojaroudi, O. A. Civi, "A Novel UWB Slot Antenna with a Self-Complementary Matching Network" IEEE, [LAPC Conf.] pp.1-15, 2015.
- [3] K. Fong Lee, K. F.Tong, "Microstrip patch antennas Basic characteristics and some recent advances" proceedings of IEEE, pp.112, 2012.
- [4] Bhomia Y., Chaturvedi A., Yadav D, "Truncated Tip Triangular Microstrip Patch Antenna", Proc. IEEE. Int Symp. Antenna Propag, vol. 2, pp. 212 - 214, 2010.
- [5] A. Deshmukh and G. Kumar, "Compact broadband Slotted rectangular microstrip antennas," IEEE Antennas and Wireless Propagation letters, vol. 8, pp.1410-1413, 2009.
- [6] Wood. C, "improved Bandwidth of Microstrip Antenna using parasitic elements," IEEE, vol.127, pp.-231-234, 11 Nov.2008,
- [7] G. Kumar and K. P. Ray, "Broadband Microstrip Antennas" New York Wiley Inc., 2002
- [8] K. L. Wong "Compact and Broadband Microstrip Antennas" New York Wiley Inc., 2002.
- [9] C. A. Balanis "Antenna Theory: Analysis and Design 2nd Edition" New York, John Wiley & Sons, 1997.
- [10] D. Sanchez-Hernandez and I.D. Robertson, "A Survey of journal, pp.60-71, broadband microstrip patch Antenna," Microwave September 1996.
- [11] Pozar D.M., Schaubert D.H., "Microstrip Antennas New York press, 1995. [12] IE3D 14.0. Zeland Software Inc., Fremont, CA.
- [12] Study of various Feeding Techniques of Microstrip Antenna Using Design and Simulation Using CST Microwave Studio.