

# SISO Antenna With and Polarization Diversity for Pattern WLAN, GPS and Satellite Applications

K MOHANA MADHU VAMSI<sup>1</sup>, A SRAVANA VENKAT<sup>2</sup>, B PAVAN KALYAN<sup>3</sup>, G VINOD KUMAR<sup>4</sup>

*Department of Electronics and Communication Engineering, Vasireddy Venkatadri Institute of Technology, Namburu, Guntur, Andhra Pradesh, India*

**Abstract-** *In the present study, a novel compact antenna system for SISO application is proposed for variety of bands (L, S and C bands). The novelty of the proposed SISO antenna system is, though the resonators are physically separated by a distance of  $0.029\lambda$  ( $\lambda$  is the free space wavelength at 5.8 GHz) equal to the thickness of the substrate (1.524 mm) used for the fabrication of the SISO system possesses good pattern diversity and polarization diversity with improved isolation without the use of any isolation enhancement techniques. Antenna system, the mutual coupling between them is acceptable. Moreover it is acceptable for different applications like GPS, Wi-Fi, and satellite communication.*

**Indexed Terms-** *Novel compact antenna; Single Input Single Output (SISO); L, S and Bands; Mutual coupling;*

## I. INTRODUCTION

Microstrip antennas were developed four decades ago and the demand for their application is continuously on the rise, especially in the last decade. The growth of this technology has boosted with the rapid rise of wireless communication technologies. They have found huge applications in the domains of defense and satellite communication. During the last decade, the cost to develop and manufacture the microstrip antenna has reduced significantly, because of the huge advancement of its technology and increasing investment in this sector commercially. The present paper deals with the design of a compact SISO antenna with decoupled radiators utilizing simultaneous pattern and polarization diversity. One of the radiators is designed for circular polarization and the other one is for linearly polarization. The designed SISO antenna also possesses good pattern diversity due to the orthogonal orientations between the radiation

maxima for the radiators. The detail design methodology is presented, and the simulation and measurement results are discussed to validate the diversity performance of the proposed SISO antenna.

## II. ANTENNA DESIGN AND IMPLEMENTATION

The Fig.1 consists of the parameters required to design the above discussing SISO antenna. The listing of resonators can be seen on the other extreme of the substrate material. For designing the antenna  $\epsilon_r = 4.4$  and  $h = 1.524$  mm are the parameters of Substrate material which we used. In table-1, all the physical parameters with its dimensions of the discussed antenna are given. The upper radiator is a square patch element with edge fed, through a quarter wave line. Using TL theory the dimensions of the square patch are calculated by satisfying the specifications of substrate.

The square patch was assimilated with corner chamfer and slot as shown in Fig.1 (a) to get circular polarization. To get a good axial ratio an off-center feed was used. It is to be considered that, moving the feed-line about the center of the patch along the edge, the impedance bandwidth is not much altered but the axial ratio bandwidth is greatly altered. The final optimized position (2.4 mm from center) of the feed-line was selected by parametric estimation. The bottom radiator is a modified inter-digital type structure and fed by a co-planar slot line. The length of each finger is half a wavelength corresponding to WLAN (5.8 GHz) frequency. The points marked "A" and "B" are the grounding and signal points respectively of the discrete port used in simulation. Length of the tapered section is optimized parametrically to achieve proper impedance matching in the desired band.

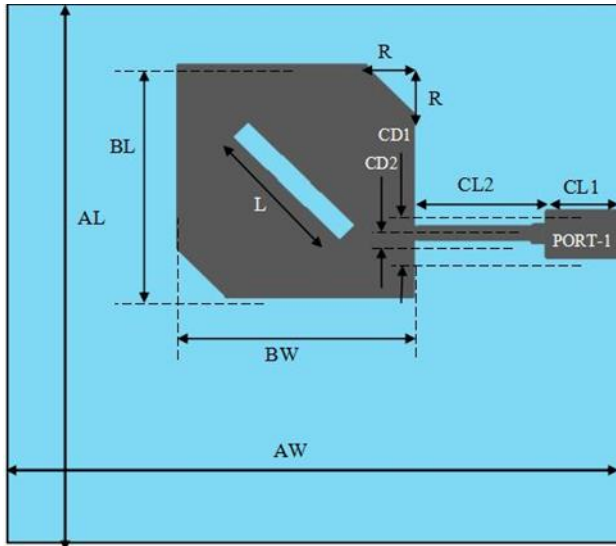

(a)

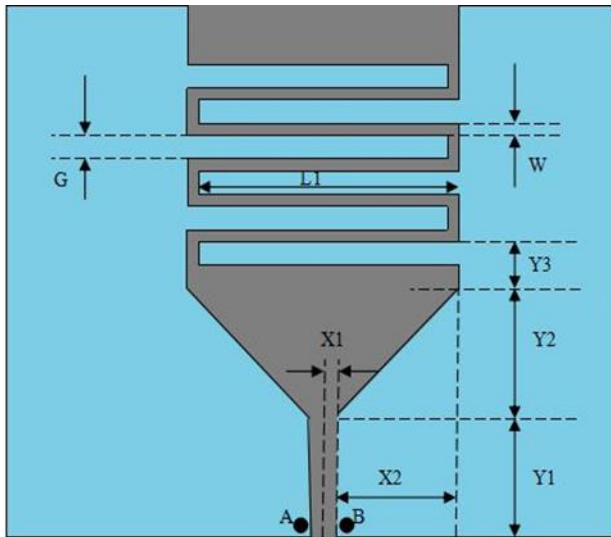

(b)

Fig. 1 Schematic of proposed MIMO antenna  
(a) Top view (b) bottom view

Table-1: Antenna design parameter [unit: mm]

AW	AL	BW	BL	L	R
30	25	11.6	11.6	6.8	2.1
CL1	CL2	CD1	X1	X2	Y1
3.1	6.1	3.0	0.5	6.0	6.0
Y2	Y3	L1	W	G	CD2
6.0	2.2	12.3	1.0	0.4	0.9

### III. RESULTS AND DISCUSSIONS

#### 3.1 S-parameter Analysis

CST Studio Suite 2014 is used for the design, Simulate and analyzes the proposed Antenna. The simulated d S-parameters is shown in Fig. 2. Here we get bandwidth of 7.2 GHz. For GPS Application (1.2 to 2.5 GHz) we get scattering parameter in range of -18dB to -20dB. WLAN (5.7 to 5.8 GHz) we get scattering parameter in range of -30dB to -60dB. Satellite Application (6.85 to 7.15 GHz) we get scattering parameter in range of -11dB to -15dB.

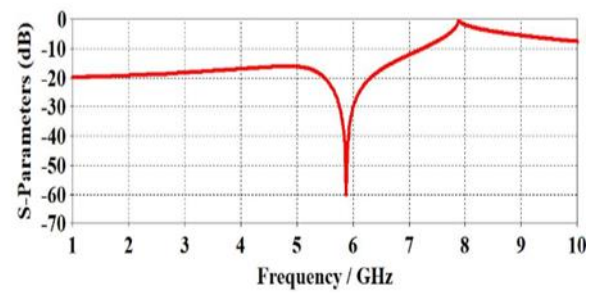

Fig.2 Reflection coefficient of the design

#### 3.2 VSWR Analysis

The simulated VSWR is shown in Fig. 3. VSWR of proposed antenna is very close to ideal value 1.001 at 5.87 GHz. And though out the frequency range it lies between 1.22 to 1.46.

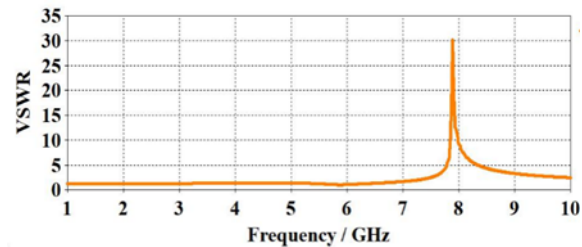

Fig.3 VSWR of the design

#### 3.3 Other Parameters Analysis

Surface current distribution, E-field, H-field, and Radiation Pattern of E-field and H-field of design are shown in Fig.4, Fig.5, Fig.6, and Fig.7 respectively.

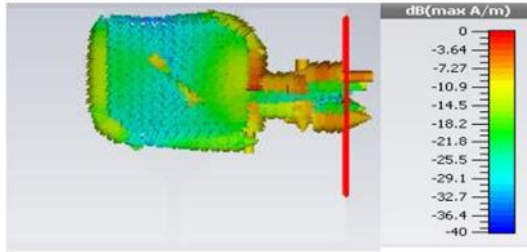

Fig.4 Surface current distribution of the design

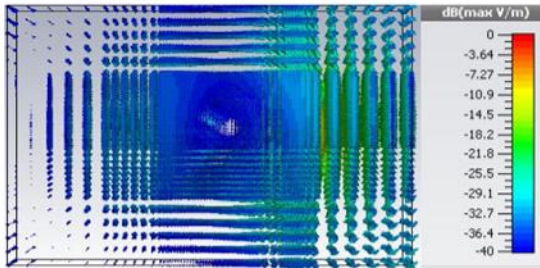

Fig.5 E-Field of the design

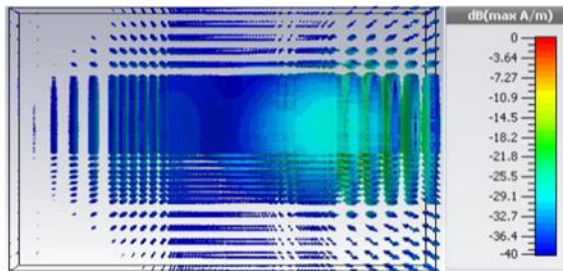

Fig.6 H-field of the design

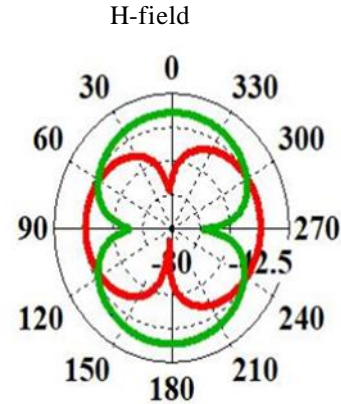
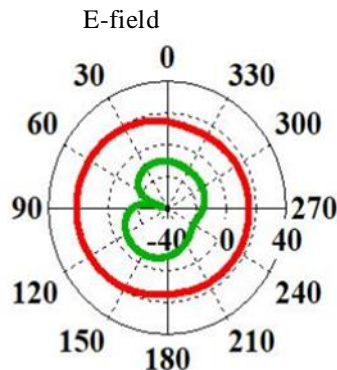

Fig.7 Radiation patterns of the design

### CONCLUSION

In this, a novel compact SISO antenna with simultaneous pattern and polarization diversity has been proposed for WLAN (5.8 GHz), GPS and Satellite applications. The present MIMO antenna is compact in the sense that the two radiators are physically separated by a distance (1.524 mm) equal to the thickness of the substrate material, still good isolation is ensured between them. The upper resonator is designed to have good CP performance, while the bottom radiator is linearly polarized. The far field radiation pattern for both radiators is orthogonal to each other, ensuring good pattern diversity performance.

### REFERENCES

- [1] J. G. Proakis, Digital Communications, New York: McGraw-Hill, 1989.
- [2] G. J. Foschini and M. J. Gans, "On Limits of Wireless Communications in a Fading Environment when using multiple Antennas," Wireless Personal Communications, 6:311-335 March 1998.
- [3] R.G. Vaughan, J. B. Andersen, "Antenna Diversity in Mobile Communications", IEEE Transactions on Vehicular Technology, vol. vt-36. No. 4, November 1987.
- [4] Forenza, A.; Heath, R.W., "Benefit of pattern diversity via two-element array of circular patch antennas in indoor clustered MIMO channels," Communications, IEEE Transactions on, vol. 54, no. 5, pp. 943-954, May 2006.

- [5] Jayasooriya, C.K.K.; Kwon, H.M.; Seok Bae; Hong, Yang-Ki, “Miniaturized Single Circular and Single Ring Patch Antenna for MIMO Communications Exploiting Pattern Diversity,” Communications (ICC), 2010 IEEE International Conference on, vol. 1, no. 5, and pp. 23-27 May 2010.
- [6] Ghosh, S.; Thanh-Ngon Tran; Le-Ngoc, Tho, “Miniaturized MIMO-PIFA with Pattern and Polarization Diversity,” Vehicular Technology Conference (VTC Spring), 2012 IEEE 75th, vol. 1, no. 5, pp. 6-9 May 2012.
- [7] Ouyang, J.; Yang, F.; Wang, Z.M., “Reducing Mutual Coupling of Closely Spaced Microstrip MIMO Antennas for WLAN Application,” Antennas and Wireless Propagation Letters, IEEE, vol.10, no., pp. 310-313, 2011.
- [8] Shin-Chang Chen; Yu-Shin Wang; Shyh-Jong Chung, “A Decoupling Technique for Increasing the Port Isolation between Two Strongly Coupled Antennas,” Antennas and Propagation, IEEE Transactions on, vol. 56, no. 12, pp. 3650-3658, Dec. 2008.
- [9] A. C. K. Mak, C. R. Rowwell, and R. D. Murch, “Isolation enhancement between two Closely packed antennas,” IEEE Trans. Antennas Propag., vol. 56, no. 11, pp. 3411–3419, Nov. 2008.
- [10] J. Byun, J. H. Jo, and B. Lee, “Compact dual-band diversity antenna for mobile handset applications,” Microw. Opt. Technol. Lett., vol. 50, no. 10, pp. 2600–2604, Oct. 2008.
- [11] H. Bae, F. J. Harackiewicz, M.-J. Park, T. Kim, N. Kim, D. Kim, and B. Lee, “Compact mobile handset MIMO antenna for LTE700 applications,” Microw. Opt. Technol. Lett, vol. 52, no. 11, pp. 2419–2422, Nov. 2010.