

Water Supply Monitoring & Controlling System with Water Theft Identification

SUSHEELA SURESH¹, SAURABH SHIRKE², VENKAT KULKARNI³, PRANAY UNNIKRISHNAN⁴,
JAYESH RANE⁵

^{1, 2, 3, 4} Student, Pillai HOC College of Engineering and Technology, Rasayani

² Assistant Professor, Pillai HOC College of Engineering and Technology, Rasayani

Abstract- According to recent study, water has become an enormous issue thanks to less rain fall, upsurge in residents. Several cities face this downside. Individuals suffer from this downside for not having decent quantity of water for daily requirements. Because of lack of surveillance, water can't be provided properly. Other difficulties are unnecessary consumption, overflow of tanks, leak in pipeline, constant water supply. High pressure of water flow will increase the likelihood of pipeline cracking. All these problems are due to lack of investigation & less workforce. Here the approach we have opted for this in-hand crisis, is using the NodeMCU 1.0 (ESP12E Module) microcontroller generally known as ESP8266 Wi-Fi Module and a 16x2 LCD Screen which will of-course play its role when the wireless transmission is out of commission. Other key components in this system are LM324AN IC and a Generic Pressure Transducer. The job of Pressure Transducer is very much clear by its name, it's simply measuring the pressure of a flowing water and convert the mechanical parameter into the voltage parameter. The more the pressure is, more will be its voltage value. LM324AN IC is actually a Quad Op-Amp. Here we have used this IC as a Comparator.

Indexed Terms- 16x2 LCD Screen, LM324AN IC, NodeMCU 1.0 (ESP12E Module), Pressure Transducer.

I. INTRODUCTION

As the population and economic process will increase the demand for water supply also will increase in day to day life. It's terribly troublesome for the enterprises to continuous monitor-and-manage the water leakage-and-stealing of water by the customers. Therefore, so as to beat this downside the urban provide water

system networks to establish the connection between water supply and intake water consumers. Hospitals and factories would like continuous provide of water in massive scale, therefore urban facility systems and public enterprises are sometimes a part of regime, take care of the continual observance and maintaining of the facility.

In order to implement the proposed water supply system, the personnel are provided with a feature of SMS from a microcontroller equipped with Wi-Fi Module to transmit the information to remote monitoring station using wireless transmitter.

Here the approach we have opted for this in-hand crisis, is using the NodeMCU 1.0 (ESP12E Module) micro-controller generally known as ESP8266 Wi-Fi Module and a 16x2 LCD Screen which will of-course play its role when the wireless transmission is out of commission. Other key components in this system are LM324AN IC and a Generic Pressure Transducer. The job of Pressure Transducer is very much clear by its name, it's simply measuring the pressure of a flowing water and convert the mechanical parameter into the voltage parameter. It does so, with the help of diaphragm inside it. The more the pressure is, more will be its voltage value. LM324AN IC is actually a Quad Op-Amp. Here we have used this IC as a Comparator. In the demo version we used three Pressure Transducer, and hence the number of sectors we are showing would also be three. Not to mention, other reason would be the availability of even a Generic version of Pressure Transducer is rare. Hence the three Op-Amps in the LM324AN IC will be used as a Comparator. The LM324AN IC requires two inputs for the comparison to take place. One input is a fixed value which is provided through potentiometer (so that the values can be determined as required) and another will be obviously from a pressure transducer.

When the compared values go off the range, the output becomes high which is connected to NodeMCU 1.0 Board. The NodeMCU is equipped with Wi-Fi module as mentioned earlier and is connected to 16x2 LCD Screen either. So, the message will be displayed on LCD Screen and a programmed message will be sent to authorized personnel.

II. DESIGN METHODOLOGY

A. Block Diagram

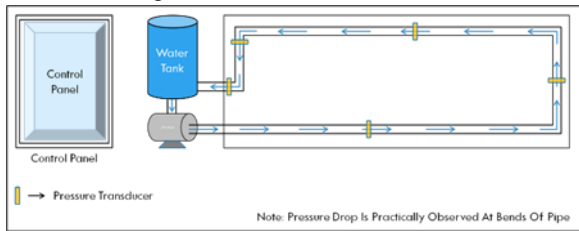

Those yellow blocks in above diagram are pressure transducers that keep measuring pressure of water flow. In the control panel, there's LM324AN IC Quad-Comparator, comparing values from pressure transducers by a range of reference voltages. The program is set to display alert message on LCD screen when the compared value falls out of range of voltages.

B. Conceptual Flow Chart

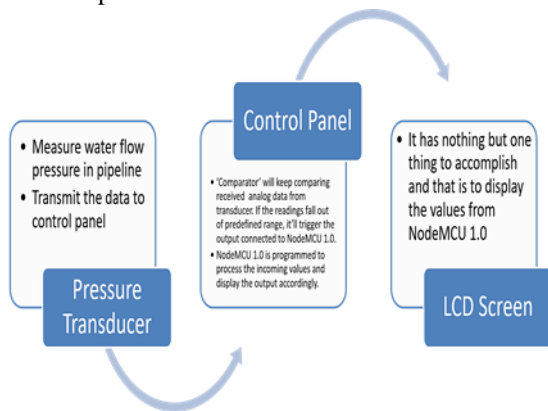

In case assume, there is a damage in the pipe, then the consequent transducer will obtain the pressure reading and it will transfer it to the comparator.

The quad-comparator will compare the values with its predefined values and when the difference in the readings are observed, the ESP8266 will alert the user.

The signals received at the Wi-fi module will generate a message which is pre-programmed and that prompt message will be sent to the user regarding the same.

C. Algorithmic Flow Chart

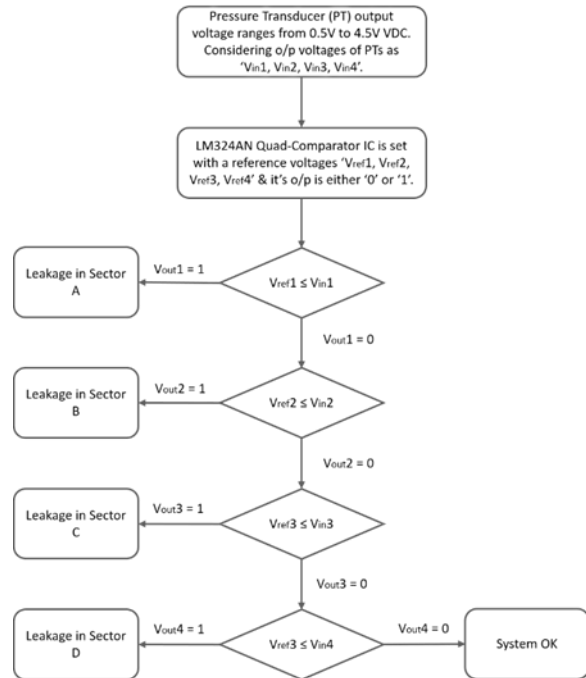

III. HARDWARE DETAILS

1. Pressure Transducer

We used a Generic Pressure Transducer for the collection and the transfer of the analog readings to the control panel. It has an operational voltage of 5V and gives its output in the range of 0.5V to 4.5V VDC. It is made up of Carbon Steel alloy which gives high pressure and tensile strength.



2. NodeMCU 1.0 (ESP-12E Module)

The NodeMCU 1.0 module is a independent SOC with incorporated TCP/IP protocol stack which will offer any small controller admittance to your Wi-Fi

network. The NodeMCU 1.0 is accomplished of either presenting subordinate application or divesting all Wi-Fi networking utilities from additional application processor. Every NodeMCU 1.0 module come from pre-programmed with associate AT command set code, significance, it will simply attach to Arduino device and get about the maximum amount Wi-Fi-ability as a Wi-Fi protect offers.



This module includes a powerful enough on-board process and storage capability that permits it to be integrated with the sensors and different application specific devices through its GPIOs with marginal development up-front and least loading throughout runtime.

3. LM324 Quad Comparator IC

The LM324 operational amplifier IC are often functioned as a comparator. This IC has four ad hoc operational amplifiers on one and only chip. This is a Low Power Quad Operational amplifier and it features high stability, bandwidth that was considered to regulator from one power provide over a large diverge of voltages. The quad amplifier will operate at provide voltages as low as 3.0 V or as high as 3.2V.



4. Motor Pump

Since the pressure transducer has a maximum handling capacity of 1 MPa, we assume a 12V DC Motor Pump.



IV. SOFTWARE DETAILS

1. Arduino IDE

The Arduino Integrated Development environment (IDE) is a cross-platform application (for Windows, macOS, Linux) that's written in functions from C and C++. It's accustomed write and transfer programs to Arduino compatible boards, but also, with the assistance of third-party cores, alternative marketer development boards. The Arduino IDE provides a computer code library from the Wiring project, that provides several common input and output procedures.[12]



User-written code solely needs 2 basic functions, for beginning the sketch and therefore the main program loop, that are compiled and coupled with a program stub main() into an workable cyclic program with the gnu tool-chain, conjointly enclosed with the IDE distribution. The Arduino IDE employs the program named avrdude to convert the workable code into a computer file in hexadecimal encoding that's loaded into the Arduino board by a loader program within the board's code.

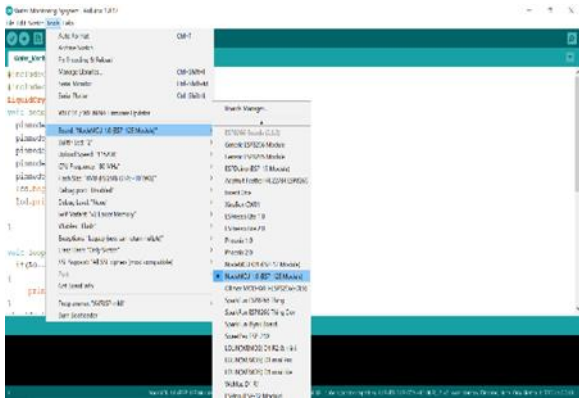

Since the NodeMCU 1.0 (ESP-12E Module) is a type of an arduino, hence we can directly burn the program over the ESP8266 using arduino IDE.

2. DipTrace [11]

DipTrace is an EDA/CAD software for creating schematic diagrams and printed circuit boards.



The designers provide a multi-lingual interface and lessons (currently available in English and 21 other languages). DipTrace has 4 modules: schematic capture editor, PCB layout editor with built-in shape-based autorouter and 3D-preview & export, component editor, and pattern editor.

2.1 Basic Features

- Simple user interface
- Multi-sheet and hierarchical schematics
- High-speed and differential signal routing
- Smart manual routing modes
- Wide import/export capabilities
- High-speed shape-based autorouter
- Advanced verifications with real-time DRC
- Real-time 3D PCB preview
- Export of PCB to STEP 3D file format
- ODB++ and Gerber (including Gerber X2) manufacturing outputs

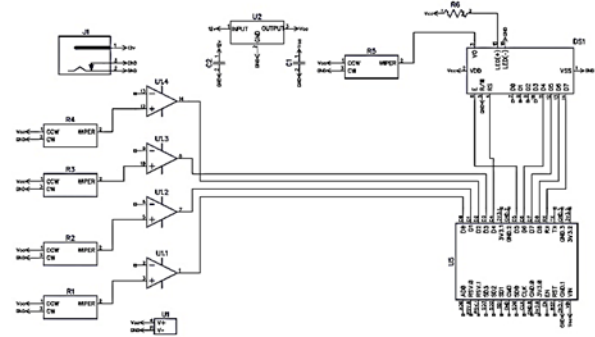

V. RESULTS

At the time when system integrity is intact, of-course there won't be any alert. But if there's to be any damage caused to pipeline by any means, so much so that the pressure is lowered to trigger the comparator output high, the program that's stored in NodeMCU 1.0 Board will send the predetermined message to the 16x2 LCD Screen and an authorized personnel via wireless means as well.

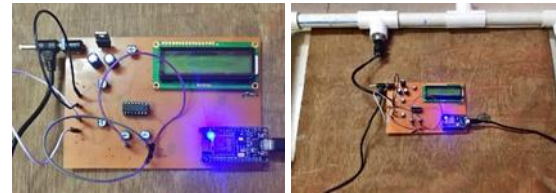

For example, if there's a crack between 2nd & 3rd pressure transducer, then the message on the either end would be "Leakage in Sector C".

CONCLUSION

Since ESP8266 Module is being used, we can implement a communication of system with authorized personnel using Wi-Fi or other technology. Automation technology can be introduced in the system to increase its efficiency. This system can also be used in the field of gas & air supply with slight alterations.

Hereby we conclude that an approach to minimize the water leak or theft was achieved to the extent that more possible room for improvable opportunities can be envisioned. It'll prove to be a relieving measure for the authorized personnel someday. By bringing this

system in a real field, we hope the count of water leak due to pipeline-crack to go minimum to none.

REFERENCES

- [1] Anil Gantala, Paparao Nalajala, N Vasudheva Reddy, and Bhavana Godavarthi, "Public Water Supply Monitoring To Avoid Tampering And Waterman Fraud Using Smart Water Meter System", *International Journal of Mechanical Engineering and Technology (IJMET)*, Volume 8, Issue 8, August 2017, pp. 1194–1201, Article ID: IJMET_08_08_119.
- [2] Gouthaman. J, Bharathwajanprabhu. R & Srikanth. A, Automated urban drinking water supply control and water theft identification system, *Students' Technology Symposium, 2011 IEEE*, 14-16 Jan, pp.87-91, 2011.
- [3] Stancel, E, Stoian, I, Kovacs, I, & Gyurka, B.Z, Urban water supply distributed control system, *IEEE International Conference on Automation Quality and Testing, Robotics*, 2008, Vol.3, pp 316-320, 2008.
- [4] Mr.Prashant Palkar , Prof. (Dr.) Shrinivas Patil, Prof. Mrs. Pooja Belagali, Mr. Ashish Chougule, Automation in drinking water supply distributed system and testing of water, *IOSR Journal of Electronics & Communication Engineering (IOSRJECE)*, pp.36-38.
- [5] J.P.Shritharanyaa, A.jagadeesan, A.lavanya Theft identification and automated water supply system using embedded technology, *IJAREEIE*, Volume. 2, Issue 8, August 2013.
- [6] N.R Kolhare, P.R Thorat, (2013) An Approach of Flow Measurement In Solar Water Heater Using Turbine Flow Meter, *International Journal of Engineering Research & Technology (IJERT)*, Volume. 2, pp. 1-4.
- [7] S.Leirens, C. Zamora, R.R. Negenborn, and B. De Schutter, Coordination in urban water supply networks using distributed model predictive control, *Proceedings of the 2010 American Control Conference*, Baltimore, Maryland, pp. 3957–3962, 2010
- [8] Shicheng Dong, Hao Jin Design of wireless monitoring system for urban water supply based on embedded technology *International Conference on Measurement, Information and Control (MIC)*, pp.348-351, 2012
- [9] Peng Jiang , Hongbo Xia , Zhiye He and Zheming Wang Design of a Water Environment Monitoring System Based on Wireless Sensor Networks Sensors, pp. 6411-6434, 2009
- [10] Paparao Nalajala, D Hemanth kumar, Intelligent Detection of Explosives using Wireless Sensor Network and Internet of Things (IOT), *International Journal of Control Theory and Applications*, Dec 2016, Volume. 9, Issue 5, pp 391-397.
- [11] <https://en.wikipedia.org/wiki/DipTrace>
- [12] <https://arduinotricks.com/different-types-of-arduino-boards/>