

Design and Development of Portable Water Cleaning System

SAHIL SHAIKH¹, PRATIK UTTARKAR², HARSH GOYAL³, SHARIK BAIG⁴, C.S. KHEMKAR⁵

^{1, 2, 3, 4} Student, Mechanical Engineering Department, ISB&M School of Technology, Pune, India.

⁵ Professor, Mechanical Engineering Department, ISB&M School of Technology, Pune, India.

Abstract- Due to the increasing rate of water pollution there is an increasing need for its awareness and cleanness. Considering this issue our project focus on cleaning of the water bodies on shore, our project is a modification of the sea-bin project according to our Indian society and needs.

We are using two buckets and one storage tank and pump will be provided at ground level, the suction will be provide at ground level due to which the water in lakes or rivers will be sucked and with water all waste will be collected in filter bag(net). The water will be pumped to higher bar pressure and it will purify for use of our people for nominal work like cleaning of cars, cleaning of house etc. while designing of whole system one disadvantage of system made us to change the design that to add submersible pressure sensor to sense the level of the water and if the level of the water is below the reference point then it will shut off the pump. The water which was stored in the tank after pumping will go into the reverse osmosis process and will be purify to better level which human can use.

Indexed Terms- Pollution, cleaning, bin, net, separation, floating.

I. INTRODUCTION

We can design an automatic bin that catches floating garbage (plastic bags, oil, fishing net, etc). We can place this bin near the seashore, boats, docks, even in lakes, ponds, etc. We can use a net that can absorb oil and can be filtered afterwards. The sea-bin is placed on the water surface where the garbage is carried by the waves. The water gets sucked into the bin with the garbage the water then will be allowed to flow into the sea back through the bottom of the bin up into the pump on the dock. As discussed earlier we can either install an oil-water separate or an oil absorbing net.

This process can be used whenever required or full time as the dirt in our water bodies cannot be removed easily. In the sea-bin we have a net that we can clean when the bag is full. In this way the collected garbage can be disposed properly after it is clean, we can use the bin again. Another advantage of this sea-bin is that it is portable and small in size, hence it can be placed wherever there is more garbage. This is a major add on to the advantages of the sea-bin as most of the current methods used are either fixed on one place or larger in size.

II. PROBLEM STATEMENT

As we know dumping of wastes in river and other water bodies is common in India, this project aims to collect floating garbage. This garbage harms the aquatic life and also causes water pollution. Most of this waste is plastic material which takes a long time to decay, is a long term to the biodiversity. This leads to water logging, formation of algae, less evaporation of water, increasing in the death rate of marine animals and many other problems.

- i. Water logging - it leads to depletion of the soil quality and due to the stagnant water there is an increase in insects and foul smell.
- ii. Formation of algae – the floating seaweeds are a great problem for marine life and due to them the evaporation rate decreases.
- iii. Effects on climate – due to formation of algae it reduces the evaporation rate and cause decrease in rainfall and other climatic changes.
- iv. Effects on marine life – Due to the contamination of water, the marine life is harmed increasing their death rate.

III. CALCULATIONS

- PUMP: -
Power: $745.7 \text{ W} = 1.0 \text{ HP}$

Head: 1 m
 Discharge: 38 lpm = 0.00063 m³/s
 Inlet pressure: 0.0011761 bar
 Outlet pressure: 12 bar

• PIPE: -
 Diameter of inlet pipe: 25 mm = 0.025 m
 Diameter of outlet pipe: 25 mm = 0.025 m
 Area: 4.90873 * 10⁻⁴ m²
 Velocity at outlet: 1.29 m/s (By continuity equation)

• Bucket: -
 Internal diameter -0.2 m
 Outer diameter - 0.3 m
 Height of bucket - 0.3 m
 Thickness of bucket -0.015 m

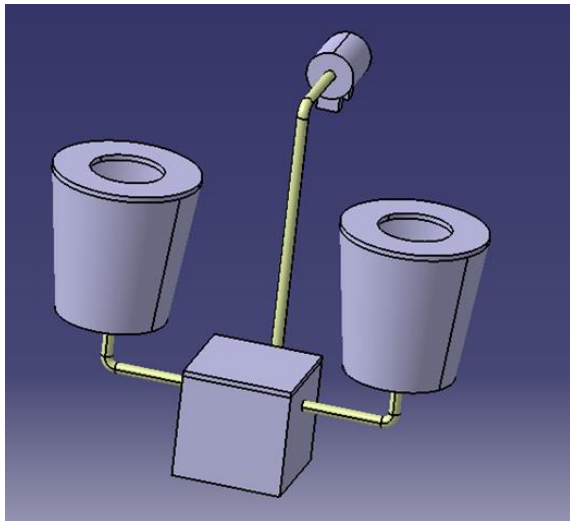

• REYNOLD'S NUMBER: -
 Characteristic Diameter:

$$D_h = \frac{4.908 * 10^4 * 4}{0.07853}$$

D_h = 0.02499 mm

$$Re = \frac{\rho v D_h}{\mu}$$

$$Re = \frac{1000 * 1.29 * 0.02499}{8.90 * 10^{-4}}$$

Re = 36.219*10³

Hence this is a turbulent flow.

• COEFFICIENT OF FRICTION: -

$$f = \frac{0.316}{(Re)^{1/4}}$$

$$f = \frac{0.316}{(36.235 * 10^3)^{1/4}}$$

$$f = 0.0229$$

• MAJOR LOSSES: -

$$h_f = \frac{4fLV^2}{2gD}$$

$$h_f = \frac{4 * 0.0229 * 2.785 * 1.29}{2 * 9.81 * 0.025}$$

h_f = 0.67 m

• BERNOULLI'S EQUATION: -

$$\frac{P_1}{\rho g} + \frac{v_1^2}{2g} + z_1 = \frac{P_2}{\rho g} + \frac{v_2^2}{2g} + z_2 + h_f$$

$$\frac{117.61}{2 * 9.81} + \frac{(v_1^2)}{2 * 9.81} + 0$$

$$= \frac{12 * 10^5}{9.81 * 1000} + \frac{(1.29^2)}{2 * 9.81} + 1 + 0.351$$

V₁ = 49.81 m/s

V₂ = 50 m/s

• MINOR LOSSES: -

Losses at entrance (from bin):

$$h_e = 0.5 \frac{v_1^2}{2g}$$

$$= 0.5 \frac{(50)^2}{2 * 9.81}$$

$$h_e = 63.71 m$$

IV. UNITS

Sr. No.	Particular	Symbols	Unit
	Power	P	W
	Horse Power	HP	hp
	Head	H	m
	Discharge	Q	m ³
	Outlet Pressure	P _o	N/m ² \ Bar
	Inlet Pressure	P _i	N/m ² \ Bar
	Area	A	m ²
	Velocity at Outlet	V _o	m/s
	Velocity at Inlet	V _i	m/s
	Reynold's Number	Re	-
	Density	ρ	Kg/m ³
	Diameter	D	m

Dynamic Viscosity	μ	Ns/m ²
Coefficient of Friction	f	-
Major Losses	h_f	m
Efficiency	η	%
Power Transmission Efficiency of Pipe	η_{pipe}	%
Gravitational Acceleration	g	m/s ²
Height from Datum of section 1-1	z_1	m
Height from Datum of section 2-2	z_2	m
Pressure at section 1-1	P_1	N/m ² \ Bar
Pressure at section 2-2	P_2	N/m ² \ Bar
Velocity at section 1-1	V_1	m/s
Velocity at section 2-2	V_2	m/s
Area at section 1-1	A_1	m ²
Area at section 2-2	A_2	m ²
Loss at Entrance	h_e	m
Loss at Enlargement	h_{e1}	m
Loss due to bends	h_b	m
Loss due to sudden contraction	h_c	m
Mass	M	kg
Speed	N	Rpm
Torque	T	N-m
Coefficient of Bending	K_b	-
Coefficient of Entrance	K_e	-
Perpendicular Distance from top of bucket to C.G.	h_2	cm
Perpendicular Distance from bot of bucket to C.G.	h_1	Cm

V. OBJECTIVES

The system aims to fight against water pollution by means of innovative technologies and educational activities for businesses. A small floating device can be helpful to solve one of the world’s biggest environmental problems.

- Collect different types of floating waste products.

- Minimize human effort in collecting the garbage from water bodies.
- It must collect maximum amount of waste. Environment friendly.
- Use of sensors makes it automatic.
- The system can be used to create and raise awareness about water pollution.

VI. WORKING PRINCIPLE

In this project the main goal of the system is to collect floating garbage from water bodies. The basic principle of the system is based on suction created by pumping action. The bucket is use as a waste collector, which collects waste due to suction pressure created by the pump. There is a proximity sensor inside each bucket to indicate us the level of waste collected. Inside the bucket there are three layer nets which help to filter water and can be removed easily without disturbing the system. We can substitute the nets and due to this the working won’t stop. There is a pressure sensor installed before the pump to indicate the clotting of garbage in the pipeline. Once we get the indication of pipeline choke up we could turn off the system immediately to avoid any damage.

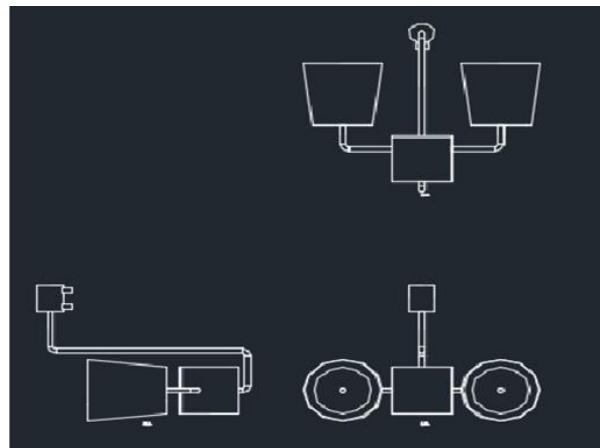

VII. FUTURE SCOPE

- Use of mobile operated android app:- In future the pump will be operated wireless and it will modify the system as no labour is required and operation will be done automatically. The sensor used in the system is submersible and is called as ‘water level detector’; there may be different kind of sensor used for this system. With the help of

mobile app we can operate the system i.e. on/off of pump can be done from a distant place.

- Use of solar and lunar power for battery: - If the pump will be operated using battery then the battery will be charged by using natural energy from sun and moon in the form of solar energy and lunar energy. We can use solar panels to charge during the day time and use the same for the pump operation in the later part of the day.
- Filtration and use of water for human needs: - If we filter the water after pumping process using reverse osmosis processes then the water from the lake or river can be used for human for their nominal work like cleaning their cars, bike, etc. It can also be used for daily household work as in washing utensils and clothes where there is no need for the clean drinkable water.
- Use of more than 2 bucket:- In previous work the designing was done for single bucket but by changing the design we created the seabin for 2 buckets so that capacity of holding the waste in the whole system may increase, so if work is done on this system in future then by changing the design they can make the seabin for more than 2 buckets. This will result in collection of more waste in one go.
- Use of extendable frame: - The framework used for the support of the system can be extendable so as to let the bin down in deeper water levels. The frame can have an additional attachment of plastic bottles and so as to lift the mechanism up with the increase in water level. This arrangement can be used form cleaning the water in deep wells or somewhere if the water surface level is lower than the ground level.
- Agricultural wastewater reuse: -Wastewater can be used for agricultural purposes such as watering landscaped gardens and lawns. It can equally be used to irrigate vegetable and fruit nurseries or flower and fence bushes.
- The use of coarse filtration: -Coarse filtration of used water can be done to improve its reuse purposes. It entails the removal of large particles in the used water such as grease, hair, plastic dirt and food just to mention a few.

CONCLUSION

Waste collecting from sea, river and lakes are the main point on which government are working on and are finding best method to clean Ganga and other sea, river which are polluted. The sea bin with double bucket was designed for same purpose. There are many proposed idea of moving system like floating boat cleaning system, boom type cleaning system and debris cleaning system. But this system is the best way to clean and store waste of the sea.

REFERENCES

- [1] Pete Ceglinski, 31 DECEMBER 2017, Cleaner marinas /cleaning oceans SEABINV5. <https://seabinproject.com/the-seabin-v5/>
- [2] Prof. Basanagouda Shivalli, PROJECT REFERENCE NO.: 40S_BE_1930, Aqua drone remote controlled unmanned river cleaning bot. http://www.kscst.iisc.ernet.in/spp/41_series/40S_awarded_&_selected_projs_further_devpt/40S_BE_1930.pdf
- [3] Saifali Sayyad, Adarsh Dorlikar, Sneha Ratnaparkhi, Nikhil Tonge, Tanvi Bhagat, Prof. Mahesh N. Buradkar, 03, March -2018, Design and Fabrication of river waste collector. <https://www.irjet.net/archives/V6/i5/IRJET-V6I597.pdf>
- [4] Shrutika Pawar, Sunita Shinde, Jyoti Fatangare, Suyanka Thorat, Vijaykumar, 05 | May 2019, Remote operated floating river cleaning machine, International Research Journal of Engineering and Technology. <https://www.irjet.net/archives/V6/i4/IRJET-V6I4711.pdf>
- [5] Rajendra Patil, Rahul Itnare, Sagar Ahirrao, Amol Jadhav, Ajay Dhumal, 04 | Apr 2019, International conference on emerging trends in engineering and management research (Harvesting Machine). International Research Journal of Engineering and Technology. <http://data.conferenceworld.in/ICETEMR/P884-894.pdf>
- [6] Technological Solutions for the Collection and Removal of Algae from the Beach, Sea and Coastal Strip in Trelleborg Municipality. <http://wabproject.pl/files/Technological%20solu>

- tions%20for%20the%20collection%20and%20removal%20of%20algae%20from%20the%20beach,%20sea%20and%20coastal%20strip%20in%20Trelleborg%20Municipality%20%20ENGLISH.pdf
- [7] Clean up Ganga KIRAN PANDYA TECHNICAL CONSULTANT WATER TREATMENT PROJECTS. <https://www.gangaaction.org/publications/clean-upGanga-howeasyisit.pdf>
- [8] Mr.Soumya, H.M. Preeti, BaswarajGadgay, October 2018, POND CLEANING ROBOT International Research Journal of Engineering and Technology. <https://www.irjet.net/archives/V5/i10/IRJET-V5I10211.pdf>
- [9] Prof. Vinayak Kale, Vishal G. Naphade, Atul M. Parande, Sunil N. Suryawansh, Muqsid M. Inamdar, 28 December 2018 DESIGN OF DISC TYPE OIL SEPERATOR, International Journal of Innovations in Engineering Research and Technology. https://www.ijiert.org/paper-details.php?paper_id=141377
- [10] LinfengPiao, Nayoung Kim, Hyungmin Park, February 2017, Effects of geometrical parameters of an oil-water separator on the oil-recovery rate, Journal of Mechanical Science and Technology. <https://link.springer.com/article/10.1007/s12206-017-0526-1>
- [11] *Mallikarjun.G.Hudedmani, Nagaraj. S. N, Shrikanth.B.J, Ali Adil, Sha, Pramod.G, march 2018, Flexible Automatic Water Level Controller and Indicator, World Journal of Technology, Engineering and Research.* https://www.researchgate.net/publication/322918493_Flexible_Automatic_Water_Level_Controller_and_Indicator
- [12] C.N.Anyanwu, C.C.Mbajorgub, E.C.Anoлиеfo, DESIGN AND IMPLEMENTATION OF A WATER LEVEL CONTROLLER, Nigerian Journal of Technology (NIJOTECH). https://www.researchgate.net/publication/272167554_DESIGN_AND_IMPLEMENTATION_OF_A_WATER_LEVEL_CONTROLLER#:~:text=An%20automatic%20regulator%20suitable%20for,as%20an%20ON%2FOFF%20switch.
- [13] BadrulAzmi Abdul Holed, Dr. MohdSazliSaad, Dr. ShayfullZamreeAbd Rahim, MohdNasir Mat Saad, PORTABLE WATER PURIFICATION SYSTEM, LAPORAN AKHIR PERSIDANGAN KAJIAN BENCANA BANJIR. https://www.researchgate.net/publication/312031830_PORTABLE_WATER_PURIFICATION_SYSTEM
- [14] Prof. Anil K Dwivedi, Pollution and Environmental Assay Research Laboratory (PEARL), RESEARCHES IN WATER POLLUTION: A REVIEW, International Research Journal of Natural and Applied Sciences. https://www.researchgate.net/publication/313426362_RESEARCHES_IN_WATER_POLLUTION_A_REVIEW
- [15] Books referred: - For calculations.
- 1) Fluid Mechanics & Hydraulic Machines R.K.Bansal.
 - 2) Fluid Mechanics -IndrajeetM.Jain.
 - 3) Turbo Machines -AnupGoel&Dr.Suhas V. Karmare.

ACKNOWLEDGEMENT

It's an advantage of the occasion of submission of Project Stage-I Report on topic "Design and Development of Portable Water Cleaning Machine". We take this opportunity to thank to our guide and faculty. We hereby express our sincere thanks to Prof. C.S.Khemkar and Prof. G.A.Ghatole for guidance and assistance during the Project stage-I Report.