

# Security System with PIR Sensor

MOE MYINT THU<sup>1</sup>, SET SET SWE<sup>2</sup>, TIN THANDAR ZAW<sup>3</sup>

<sup>1, 2, 3</sup> *Engineering Physics Department, Yangon Technological University*

***Abstract- Nowadays, the undesired security attack on offices, banks, companies, homes, etc. is getting increased in most of the cities. For such areas, the security system is essential part. The effective and reliable detection for intruder with lighting and alarming system becomes popular. With the help of advanced technology, any motion can be detected by measuring the changes of temperature or speed within the particular area or environment. The focus of this paper is the development of home security system using motion detector PIR sensor. The system can detect the intruder by reinforcing the surveillance technique which provides the important security with necessary control and alarming. If any suspicious case within the particular surrounding, PIR sensor senses the movement around the sensor. The sensing pulse forces to activate the light switch and sound alarm. The advantage of Security system using PIR sensor method is which enables to detect without any warning feedback for any suspicious object.***

***Indexed Terms- Home security system, PIR sensor, Automatic Room Light***

## I. INTRODUCTION

Due to the undesirable action of human such as attempting to trespass and behavior of destructiveness, the degree of security level is in serious in many areas. The security degree is necessary to take into account for protection of such danger, and criminals. The people of today are struggling for their lives. Therefore, the necessity of home security is essential to provide by controlling the devices at home remotely and keeping surveillance over their home.

On the past days, a closed-circuit television (CCTV) is one of the solutions for security. CCTV can capture the event in real time for 24 hours which occurs around the environment as a streaming video. The installation of such device is expensive and it is difficult to maintain.

As the changing of the technology, the internet of things (IoT) method has become popularity due to its convenient to use. Internet of things (IoT) can access data in real time via the phone or laptop easily. IoT is a network communication that capable of sending data without interference or without any intervention. Therefore, most of the security monitoring system based on the IoT is very preferable than other. Most of the implemented home security system utilizing the sensor, such as passive infrared (PIR), Ultrasonic sensor, sensor light dependent Resistor (LDR) and so on.

The implemented system of this paper of design is simply electronic circuit without microcontroller. In this design, PIR sensor is used. If there's any intruder enters their home, the mechanism feedback of the electronic circuit to alert the house owner. PIR sensor is also known as motion detector. It can detect the motion of the object such as human. After the motion of object is detected, the automatic of light and alarm are activated simultaneously. The system can acknowledge the intruder accurately in shortest time, but the usage of PIR sensor has limited range for detection process.

## II. BACKGROUND THEORY

With the help of advance technology, the model of the security system can be designed as necessary. Among the most of the designs, the security system using motion detection alarm is very easy to install and difficult to destroy. It is able to control doors and motion sensor. The motion sensor (PIR) used in this design is based on pyroelectric device. It detects motion by measuring changes in the infrared levels emitted by surrounding objects and the speed of motion of object.

In the security system with PIR sensor, the IR radiation transmits from the sensor and it is received by the receiver. When something past through the sensor, the transmitter part emits the radiation and

after receiving the radiation, the concerning electrical pulse activated the alarm and other electronic device. But this technique has limited range and poor line of sight [4].

Passive Infrared PIR Sensor modules are now widely used in many electronic circuits. Most of the motion detector devices are constructed by using these ready-made and pre-configured PIR sensors. Because a motion detector based on the PIR sensor can detect the movement of humans, animals, or other objects, it commonly utilizes in most security system such as burglar alarm, automatically-activated lighting systems and so on. PIR sensors detect general movement by changes of infrared radiation without giving information on whom or what moved. For that purpose, an electronic controlled circuit is required to active the alert electronic devices.

PIR sensor works on the change of infrared radiation causes the change of temperature or heat of human. It varies sensing of the temperature or heat, in the detecting the amount of change of infrared radiation. When person passes through the range of sensing area, the temperature in the sensor's field of view will rise at that time. The changing result of the infrared radiation converts into a change in the output voltage. The change of voltage provides triggers for the feedback control system. The activation of the alarm and light is due to this triggering. The sense of temperature range cannot the same because the emission of infrared pattern is not the same for different surface. But the sensing rate and time can be adjusted in the sensor module.

The main objective of this paper is to design a security system which can detect human movement, switches light and buzzes an alarm when there is a strange case. When intruder comes in, PIR sensor senses the motion and temperature of such human and notifies the detection to the owners immediately. This design is very cost effective and it can be installed anywhere in the house. The proposed design is quite efficient and convenient to use for homes and other areas.

### III. PIR SENSOR AND OPERATION

There two types of PIR sensors: active type and passive type. As a feature of PIR sensor, it is

a radiation source which is sensitive to interruptions of radiation sense. A passive PIR, which does not have IR source, acts as a motion detector. It receives infrared, not emits. The passive term refers for the fact that PIR devices don't radiate energy for detection purposes.



Figure 1. PIR Sensor

A passive infrared sensor (PIR sensor) work just by detecting infrared radiation (radiant heat) emitted by or reflected from objects. When one object moves across the setting area of PIR detector, it can detect heat of radiation emitted by an object, such as animal or human. Because of simple type, reliable, and low price, the PIR sensors have tons of benefits compared with other sensors. Passive Infrared Sensor (PIR) can be used as a useful module. For this feature, PIR sensors are commonly called simply "PIR", or sometimes "PID" which means that "passive infrared detector". They can measure infrared (IR) light radiating from objects in its field of view. Therefore, PIR sensors are mostly utilized in security alarms and automatic lighting applications. Generally, PIR sensor detects any change in heat, and its output PIR becomes HIGH, whenever it detects any change.

For motion detectors, it is required to get approaching within a full  $360\pm$  field of view. For directing the infrared ray from the outlying, it is necessary to adjust the narrower angular of the sensor point to reach the specified field of view. The motion detectors require complicated optical arrangements because of having limited field of view. Optical arrangements bring the incident radiation to the right sensor at the right angle to be perceived. Motion detectors with wide fields of view have complexity and high in cost, and compact in physical size unit.

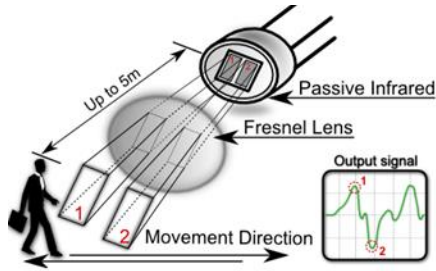

Figure 2. Operation principle of PIR sensor

A. Areas of Applications of PIR Sensors

- All outdoor Lights for security system
- Multi Apartment Complexes

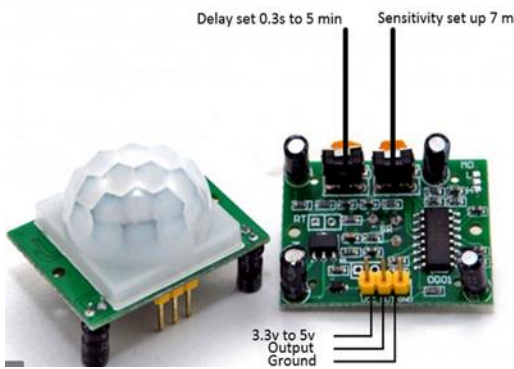

Figure 3. Pin diagram of PIR Sensor

- For Basement or Covered Parking Area
- Shopping Malls for in-out system
- For garden lights switching
- Lift Lobby
- Common staircases

B. Features

1. Dual Element Sensor with Low Noise and High Sensitivity.
2. Motion Detection Complete with PIR
3. Delay Time Adjustable.
4. Supply Voltage – 5V.
5. Standard TTL Output.

IV. PIR MOTION SENSOR DESIGN

In the PIR sensor design, the plastic window is used for the housing of the sensor module to prevent surface from touching. The using of plastic window can protect the entering of strange objects (dust, insects, and so on.) from disturbing the sensor's field of view, damaging the mechanism, and/or causing some error

signals. Although it doesn't penetrate the glass, the module is sensitive to the wavelength of infrared radiation. If the housing is made with glass, a robust penetration i.e. high intensity of light can affect the sensing process. This glass type of housing is suitable to use a public side-area but it is not good for indoor area.

By using the plastic housing, the infrared radiation enables to be transparent for detection. To use the PIR sensor module as an infrared sensor, the window is a filter to prevent the entering radiation of wavelength 8-14 micrometers, which is closest to the infrared radiation emitted by humans.

Being a temperature sensing device, such PIR sensor should not be used in the area of blowing hot or cold air area. Because getting hot causes the plastic housing window to increase temperature, when the hot or cold air incident onto the surface of the plastic. The changing of plastic's temperature is enough to trigger and it cause sensing and unnecessary condition or error can occur in this case.

The sensitivity threshold level can be adjusted as necessary. By adjusting a higher sensitivity threshold for the focus area, the sensor can be detected to be required output. By doing so, the sensor's detection designed "ignore" domestic pets, like dogs or cats.

The module of PIR Pin diagram is shown in Figure 3. There are 3pins; Vcc, Data pin and Ground. The PIR sensor can be connected in interfacing with microcontroller easily. The operation of PIR sensor module can do two types of function, measuring the changes of temperature for movement of human. In a Data pin, the PIR can operate as a digital sensing output, such as high or low pulse. For the motion of the object, the Data pin of PIR sensor outputs a high signal on a signal I/O pin. PIR sensor produces timing pulse based on the warming up the temperature. The duration of warm-up time pulse will be within 10s-1 minute. The timing frequency can be controlled by adjusting the built-in preset in the module. The detection range of PIR can be extended up to 10 meter. In the process of detecting, when the sensor detects the normal temperature the output remains low, and once the output gets to high when there is a motion because of changing temperature and then it returns to low. The

motion continues the output will cycle during this manner until the temperature is stable. The security systems using PIR are also applicable in outdoor security and motion-sensitive lighting with low power consumption.

Because the PIR sensor operates in a differential mode, a pair of complementary pulses is processed at the output pin of the sensor, when a movement is detected within the focus of the sensor. The output of the differential signal is rectified and fed to a relay driver circuit because the output of the sensor is connected with some activation device such as relay or a data logger, or an alarm, or light. At once the system receives the signals from the PIR, the relay contact opens and activates to the attached load and gives acknowledging pulse that a person is detected within the restricted area.

In the security system with light switch, the PIR sends a pulse to control the relay module to be capable of switching mains voltage. Therefore, in the outdoor system when movement is detected, light connecting to the PIR is ON and causes to turn on the front entrance light or other security alert light. The PIR based lighting system also provides the energy saving system. Because the lights are only alive when it is necessary and the lights are turning off when there is no person or when people leave such focus area.

V. OPERATION OF THE SECURITY SYSTEM

The constructed model design of security system is divided into five parts. There are

- Sensor unit,
- Op amp for Amplifier part,
- Comparator,
- Switching control part, and
- Relay module for activation of the system

The block diagram of the PIR based security system is given below.

As shown in the block diagram (Figure 4), PIR sensor module is use as a sensor unit to detect the incoming radiation. When the sensor unit detects the changes of infrared radiation, it generates an electric pulse. According to the related the sensing effect, the output of the sensor unit generated a change in the voltages.

But the changing of voltage level is not enough to operate for the remaining task. It is necessary to amplify. The part of the Op-amp in the block diagram is to do the task for amplifying the voltage. Therefore, the voltage is amplified to be measured by an on-board amplifier and the measured voltage is compared with the reference source by the comparator. The resultant voltage pulse is fed to the switching control part of the system. In this stage, transistor is employed as a switch. Based on the detection of the PIR sensor, the transistor operates to activate the relay unit for lamp and security alarm to be alive. When the people enter the entire detecting area, or there is strange case in the focus of the region, the transistor is ON and causing security lamp and alarm turning on through from the activation of Relay module. But if there is no suspicious condition, the transistor is OFF and the inactivation relay causes turning the alert system, lamp and alarm, off in this condition.

The circuit diagram of the constructed security system is shown in Figure 5. In the constructed

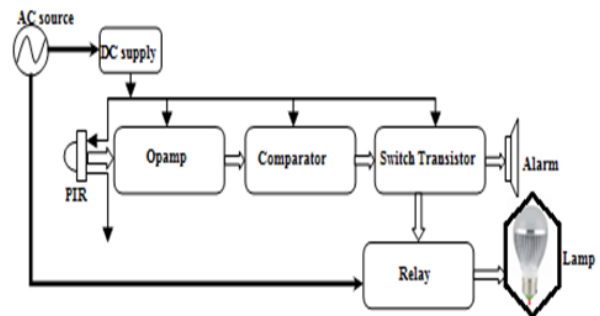

Figure 4. Block diagram of security system

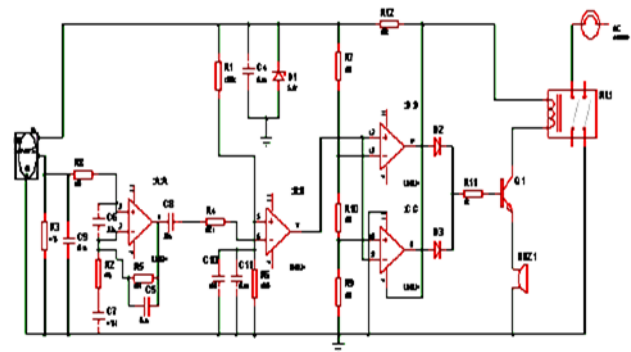

Figure 5. Circuit diagram of security system

circuit of the system, LM 324 is used as two stage op amp amplifier. Because the output signal from the PIR sensor is very low, it is required to amplify by using LM324. From the quad Op amp type of LM 324 IC, the first two op amps are use as amplifier. The rest of the Op amps; 3<sup>rd</sup> and 4<sup>th</sup> Op amps are operating as comparator. These comparators compared the output signal of the amplifier with the reference voltage. When the sensor gets detection, the output of comparator goes HIGH. After receiving the HIGH pulse from comparator, the transistor Q1 goes HIGH for ON state, and sends to relay module for activation. Then the energized relay provides to cause the alarm and lamp to turn ON. DC supply is required for relay switch and 5Volt DC is for lamp and alarm. As a result, the 12V DPDT relay is energized to power the red LED through current limiting resistor R3. The red LED and the relay remain ON for a duration based on the time setting, from 5 s to 1 Minutes. The operation of circuit is shown below.

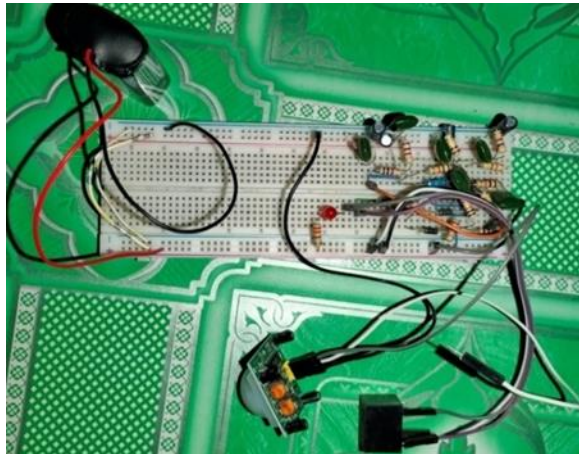

Figure 6. Before detection

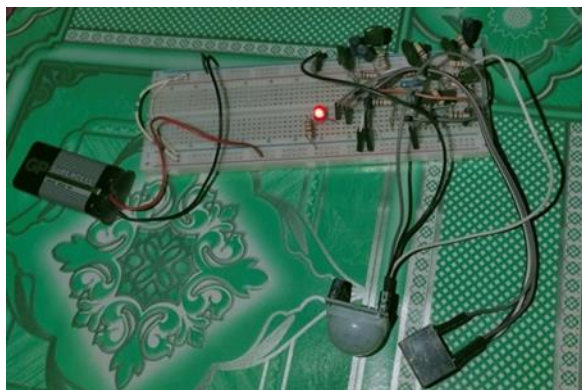

Figure 7. After detection

VI. RESULTS

Based on the sensitivity of PIR sensor, the detected ranges of the system are measured with three level; maximum, medium and minimum level. The obtained measurement data are shown in the tables respectively.

Table 1. Maximum sensitivity data of system

Detecting Distance (m)	Switch & Relay	LED indication	Lamp & Alarm
2	ON	ON	ON
4	ON	ON	ON
6	ON	ON	ON
8	ON	ON	ON
10	OFF	OFF	OFF

Table 2. Medium sensitivity data of system

Detecting Distance (m)	Switch & Relay	LED indication	Lamp & Alarm
2	ON	ON	ON
4	ON	ON	ON
6	ON	ON	ON
8	OFF	OFF	OFF
10	OFF	OFF	OFF

Table 3. Minimum sensitivity data of system

Detecting Distance (m)	Switch & Relay	LED indication	Lamp & Alarm
2	ON	ON	ON
4	ON	ON	ON
6	OFF	OFF	OFF
8	OFF	OFF	OFF
10	OFF	OFF	OFF

CONCLUSION

For the whole system, the PIR sensor is the heart of the project. The human motion across the entire area can detect by altering the infrared radiation by means of passive infrared sensor (PIR). The uses of PIR sensor are very applicable for security. In addition, the design of the system is efficient in energy consumption and it also applicable in the area of low energy supply or inadequate electricity supply. The operation of the circuit is simple and easy to install in any condition.

Due to its good response to the motion detector, the proposed security system is suitable for home surveillance application.

#### ACKNOWLEDGEMENT

I thank all of the teachers who directly or indirectly helped us to complete this paper. I would like to thank all of my friends, Department of Physics, Yangon Technological University for their various kinds of help.

#### REFERENCES

- [1] <https://www.elprocus.com/pir-sensor-basics-applications/>
- [2] Nico Surantha, Wingky R. Wicaksono. "Design of Smart Home Security System using Object Recognition and PIR Sensor", *Procedia Computer Science*, 2018
- [3] Charadva MJ. A Study of Motion Detection Method for Smart Home System *GENERAL*. 2014;1(5):148–51.
- [4] Chuimurkar RM, Bagdi V, Professor A. Smart Surveillance Security & Monitoring System Using Raspberry PI and PIR Sensor. *Int*
- [5] Kumar AS, Reddy PR. An Internet of Things approach for motion detection using Raspberry-Pi. *J Int J Adv Technol Innov Res*. 2016;8(19):3622–7.
- [6] <http://www.circuitstoday.com/pir-sensor-based-security-system>
- [7] [https://howlingpixel.com/en/Passive\\_infrared\\_sensor](https://howlingpixel.com/en/Passive_infrared_sensor)
- [8] <https://infosec2016.wordpress.com/2016/02/08/advanced-security-guard-with-pir-sens>