

Design And Finite Element Analysis for Static and Dynamic Behaviour of Composite Shaft

D.MERWIN RAJESH¹, B. HARI KRISHNA², K. LOKESHWAR REDDY³, SHAIK ABDUR REHMAN HUSSAIN⁴, M. SRINIVASULU⁵, B. RAMAKRISHNA REDDY⁶, ACHUKATLA SHAIK FAZAL⁷

¹ Assistant Professor, Department of ME, KSRMCE (Autonomous), Kadapa, AP, India

^{2, 3, 4, 5, 6, 7} Student, Department of ME, KSRMCE (Autonomous), Kadapa, AP, India.

Abstract- Drive shaft has a major role in vehicle transmission system. It is a mechanical part which is used to transfer power from engine to wheel. Almost all automobiles have transmission shafts. Drive shafts, as power transmission tubing are used in many applications including cooling towers, pump sets, aerospace, trucks and automobiles. In Front wheel drive (FWD) car, maximum power is transmitted through drive shaft. This power transmission mainly depends on size of drive shaft. The drive shaft is subjected to torsional stresses and bending stresses. To achieve more reliability, less cost and high quality, the drive shaft should be with less weight and more strength and stiffness. Because of this reason weight optimization of front wheel drive shaft plays a major role in achieving these major goals like less cost, high quality and reliability.

This project deals with the design of front wheel drive shaft for maximum power transmitted from FWD car. This project includes detailed finite element analysis of front wheel drive shaft for torsional and bending loads. The project involves performing analysis for drive shaft with conventional steel and composite (E-GLASS/EPOXY and HM Carbon/Epoxy) materials. In this project, the design of front wheel drive is done by theoretical formulas for steel and composite (E-GLASS/EPOXY and HM Carbon/Epoxy) materials for torsional and bending loads. Design of front wheel drive shaft is done in NX CAD software and Ansys software is used for static and modal analysis of front wheel drive shaft.

Indexed Terms- Bending stresses, conventional steel, E-Glass/Epoxy, HM Carbon/Epoxy, Torsional stresses

I. INTRODUCTION

A driveshaft or driving shaft is a device that transfers power from the engine to the point where work is applied. In the case of automobiles, the drive shaft transfers engine torque to the drive axle, which connects the two wheels together on opposite sides and with which they turn. The driveshaft is also sometimes called propeller shaft. Drive shafts are essentially carriers of torque. Before they became a vogue, older automobiles used chain drive and even generators to transmit power to the wheels. Drive shaft today, however, has U-joints, devices which help them to move up and down during suspension. Some driveshaft's also have another kind of joint, called slip joints, which allow them to adjust their lengths to the movement of the suspension.

Adjustments aside, drive shafts are of different lengths depending on their use. Long shafts are used in front-engine, rear-drive vehicles while shorter ones are used when power must be sent from a central differential, transmission, or transaxle. Because of the load they Carry, driveshaft must be strong enough to bear the stress that is required in the transmission of power.

• TYPES OF DRIVE SHAFTS:

There are different types of drive shafts in Automobile Industry:

1. One-piece driveshaft
2. Two-piece driveshaft
3. Slip in Tube driveshaft

• CONSTANT VELOCITY (CV) JOINT:

CV joint accommodates angular changes more effectively between ends of one-piece drive shaft. For front wheel drive systems, the short distance between wheel hubs and final drive housing. Combined with a large movement of wheel due to suspension deflection

and steering angle i.e., maximum drive angle of universal joints is great. A CV joint at each end of drive shaft meets the angle requirement.

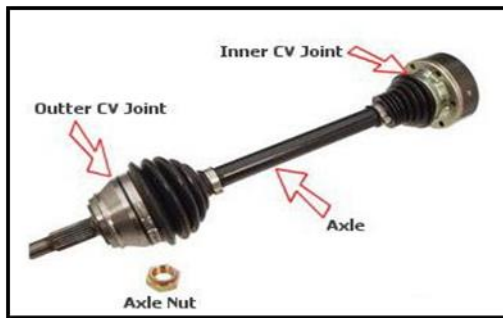

Fig.1: One-piece drive shaft

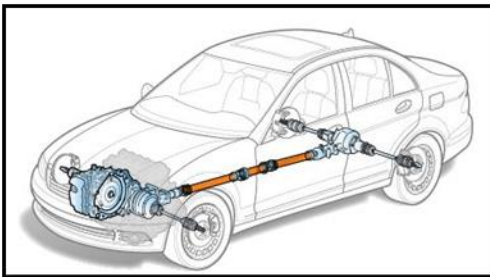

Fig.2: One-piece drive shaft in vehicle.

II. LITERATURE REVIEW

This paper presents Drive shaft is the main component of drive system of an automobile. Use of conventional steel for manufacturing of drive shaft has many disadvantages such as low specific stiffness and strength. Conventional drive shaft is made up into two parts to increase its fundamental natural bending frequency. Two-piece drive shaft increases the weight of drive shaft which is not desirable in today's market. Many methods are available at present for the design optimization of structural systems and these methods based on mathematical programming techniques involving gradient search and direct search. These methods assume that the design variables are continuous. But in practical structural engineering optimization, almost all the design variables are discrete. This is due to the availability of components in standard sizes and constraints due to construction and manufacturing practices.

III. PROBLEM DEFINITION AND METHODOLOGY

• Problem Definition:

In Front wheel drive (FWD) car, maximum power is transmitted through drive shaft. This power transmission mainly depends on size of drive shaft. The drive shaft is subjected to torsional stresses and bending stresses. To achieve more reliability, less cost and high quality, the drive shaft should be with less weight and more strength and stiffness. Because of this reason weight optimization of front wheel drive shaft plays a major role in achieving these major goals like less cost, high quality and reliability. Composite materials are playing major role in optimization of weight of shaft.

• METHODOLOGY:

- Design of one-piece drive shaft was done through NX CAD software.
- Designed one-piece drive shaft was imported in Ansys software.
- Finite element analysis of one-piece drive shaft was done in Ansys software.
- Performance analysis of drive shaft pass through Ansys software with conventional steel material and also with composite E-glass/Epoxy and HM Carbon/Epoxy materials for torsional loads.
- A static, model analysis of drive shaft is done with the help of Ansys software for different materials (steel, E-glass/Epoxy and HM Carbon/Epoxy) to calculate weight, deflections, stresses of the drive shaft.
- Results obtained from the analysis are compared and the best material is proposed based on the weight to strength ratio.

IV. DESIGN OF STEEL DRIVE SHAFT

Calculation of Torque transmission capacity of One-piece drive shaft:

Input:

Outer diameter of shaft (D_o) = 50 mm

Inner diameter of shaft (D_i) = 30 mm

Length of shaft (L) = 442.1 mm

Material Properties:
 Material used for drive shaft is Stainless steel alloy:
 Young's Modulus: 200 GPa
 Poisson's Ratio: 0.3
 Density: 7850 Kg/m³
 Yield strength: 300 MPa
 Element Types used:
 Name of the Element: SOLID 187
 Number of Nodes: 10
 DOF: UX, UY & UZ

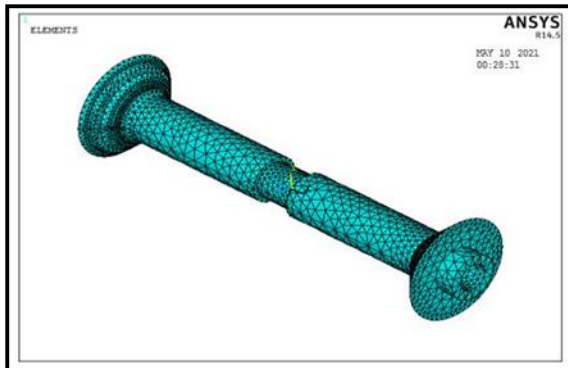

Fig.7: Meshed model of drive shaft

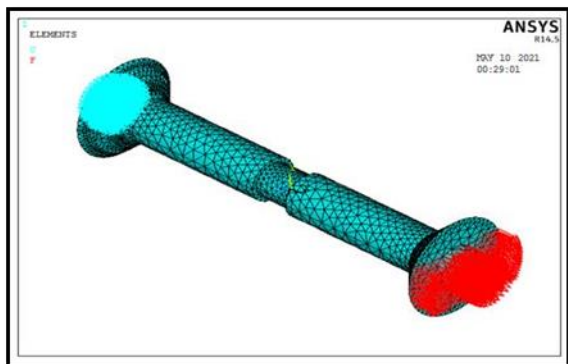

Fig.8: Applied boundary conditions on cylindrical bearing

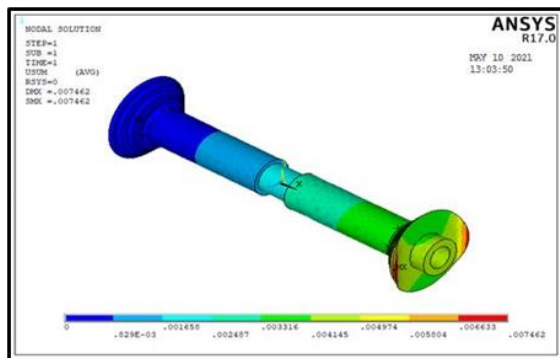

Fig 9: Resultant displacement of drive shaft.

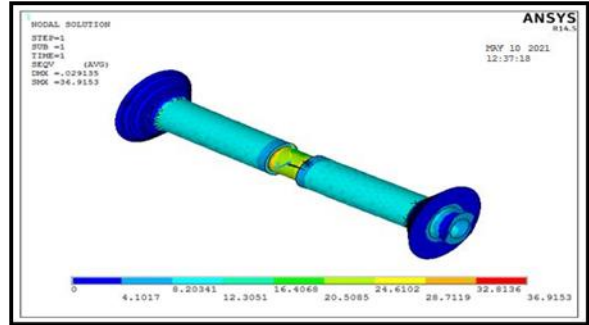

Fig.10: Von misses Stress formed on shaft

From static analysis results for steel material, the resultant displacement found on one-piece drive shaft is 0.029 mm. The Von misses stress formed on drive shaft is 36.91Mpa. The yield strength of steel material is 300 MPa. The Von misses stress of drive shaft was less than the yield strength of the material. Hence the drive shaft was safe in design for static conditions.

MODEL (DYNAMIC) ANALYSIS OF DRIVE SHAFT USING STEEL MATERIAL:

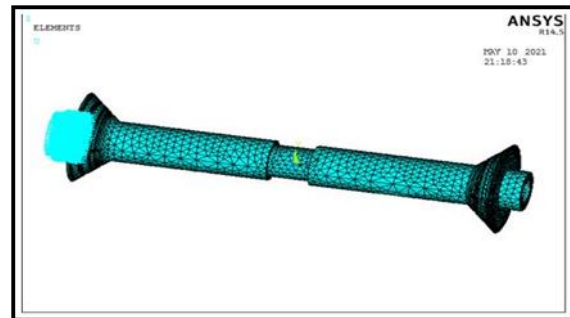

Fig.11: Applied fixed load on drive shaft

```

**** INDEX OF DATA SETS ON RESULTS FILE ****
SET  TIME/FREQ  LOAD STEP  SUBSTEP  CUMULATIVE
 1  178.83      1          1         1
 2  179.02      1          2         2
 3  1155.5      1          3         3
    
```

Fig.12: Natural frequency results.

1) Mode shape@ 178.83 Hz:

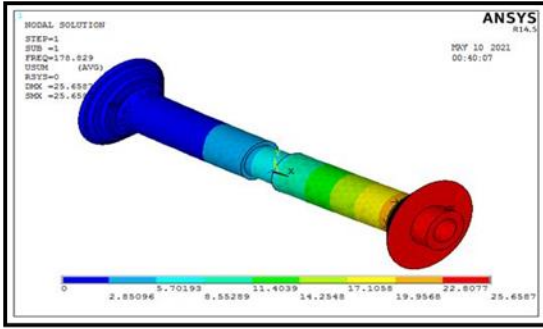

Fig.13: Mode shape of drive shaft @ 178.83 Hz

2) Mode shape@ 179.02 Hz:

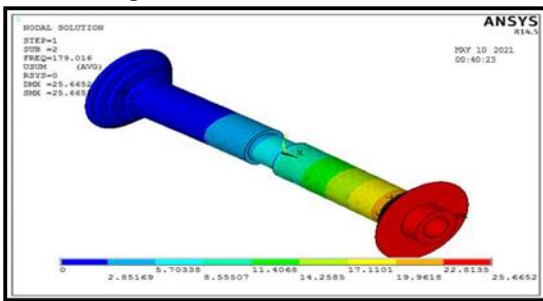

Fig.14: Mode shape of drive shaft @ 179.02 Hz

3) Mode shape@ 1158.48Hz:

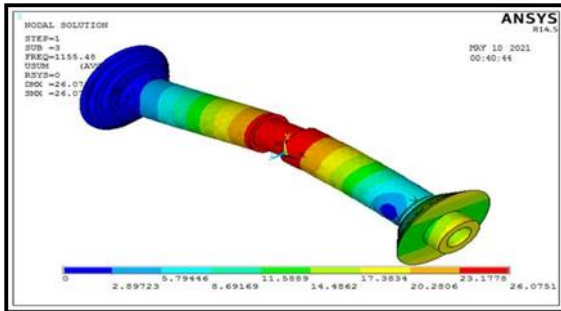

Fig.15: Mode shape of drive shaft @ 1158.48Hz

8. ρ Kg/m³ 2000.0

Table.2: Material properties for Composite Materials (E-Glass/Epoxy)

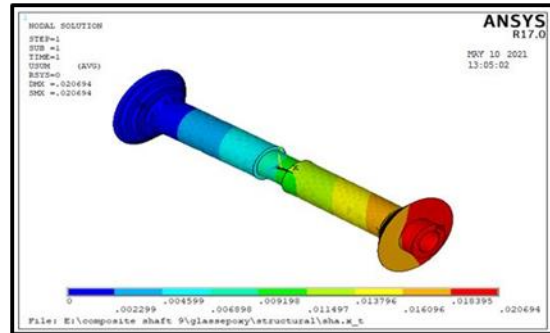

Fig 16: Resultant displacement of drive shaft

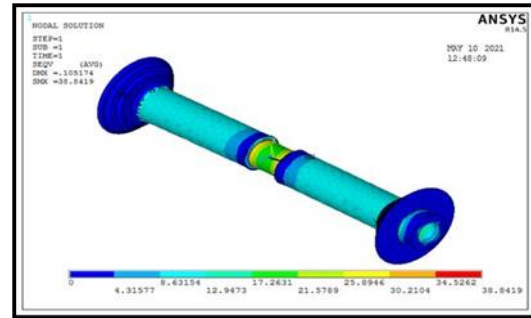

Fig.17: Vonmises Stress formed on drive shaft

From static analysis results for E-glass epoxy, the resultant displacement found on drive shaft is 0.105mm. The Von misses stress formed on drive shaft is 38.84MPa. The yield strength of E-glass/Epoxy material is 870 MPa. The Von mises stress of drive shaft was less than the yield strength of the material. Hence the drive shaft was safe in design for static conditions.

STATIC ANALYSIS OF COMPOSITE MATERIALS (E-Glass/Epoxy) USED FOR ONE-PIECE DRIVF SHAFT:

S. No	Property	Units	E-Glass/Epoxy
1.	E ₁₁	GPa	50.0
2.	E ₂₂	GPa	12.0
3.	G ₁₂	GPa	5.6
4.	ν_{12}	-	0.3
5.	S ₁ ^t = S ₁ ^c	MPa	800.0
6.	S ₂ ^t = S ₂ ^c	MPa	40.0
7.	S ₁₂	MPa	72.0

***** INDEX OF DATA SETS ON RESULTS FILE *****				
SET	TIME/FREQ	LOAD STEP	SUBSTEP	CUMULATIVE
1	313.62	1	1	1
2	314.14	1	2	2
3	599.63	1	3	3

Fig.18: Result frequencies for E-Glass/Epoxy material.

1) Mode shape @ 313.618 Hz:

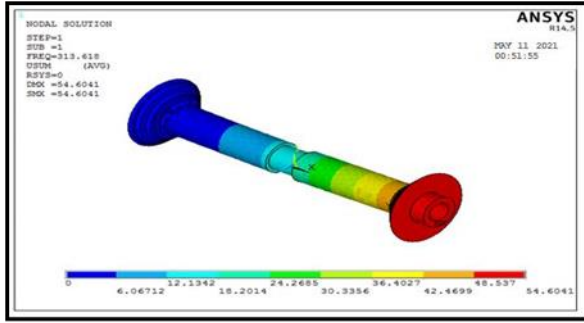

Fig.19: Mode shape of drive shaft @313.618 Hz

2) Mode shape @ 314.14 Hz:

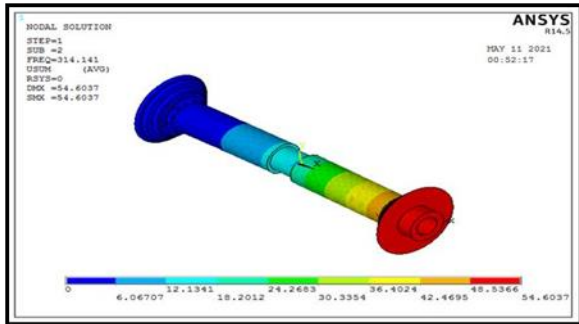

Fig.20: Mode shape of drive shaft @314.14 Hz

3) Mode shape @ 599.63Hz:

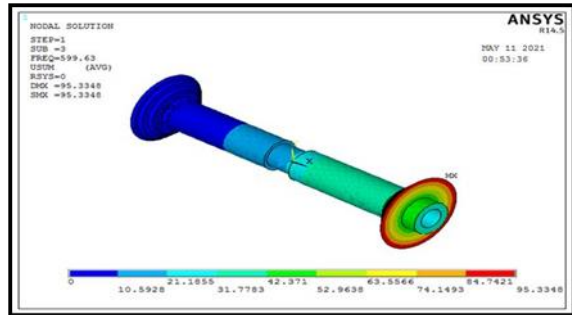

Fig.21: Mode shape of drive shaft @599.63 Hz

STATIC ANALYSIS OF COMPOSITE MATERIALS (HM Carbon/Epoxy) USED FOR ONE-PIECE DRIVE SHAFT:

S. No	Property	Units	HM Carbon/Epoxy
1.	E ₁₁	GPa	190.0
2.	E ₂₂	GPa	7.7
3.	G ₁₂	GPa	4.2
4.	ν ₁₂	-	0.3
5.	S ₁ ^t = S ₁ ^c	MPa	870.0
6.	S ₂ ^t = S ₂ ^c	MPa	94.0

7.	S ₁₂	MPa	30.0
8.	ρ	Kg/m ³	1600.0

Table.3: Material properties for HM carbon/Epoxy material

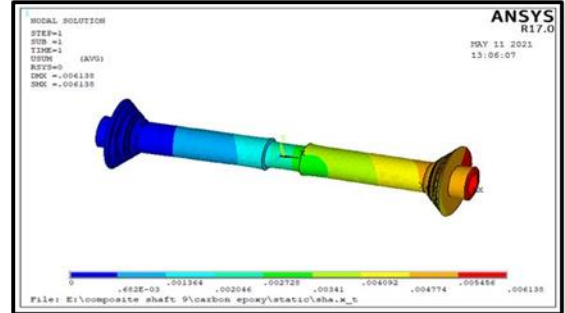

Fig.22: Resultant displacement of drive shaft.

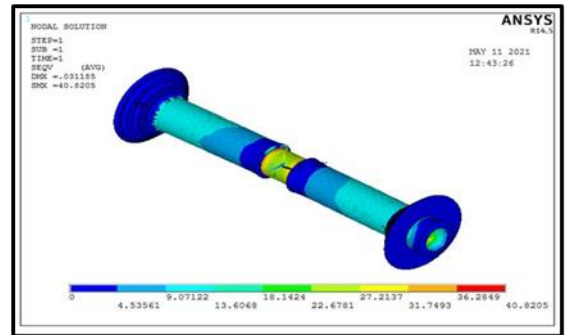

Fig.23: Von mises Stress formed on drive shaft

From static analysis results for HM Carbon /epoxy, the resultant displacement found on drive shaft is 0.0311mm. The Von mises stress formed on drive shaft is 40.82MPa. The yield strength of Carbon/Epoxy material is 870 MPa. The Von mises stress of drive shaft was less than the yield strength of the material. Hence the drive shaft was safe in design for static conditions.

**** INDEX OF DATA SETS ON RESULTS FILE ****				
SET	TIME/FREQ	LOAD STEP	SUBSTEP	CUMULATIVE
1	313.78	1	1	1
2	314.01	1	2	2
3	599.67	1	3	3

Fig.24: Result Frequencies for HM Carbon/Epoxy material

1) Mode shape@ 313.78 Hz:

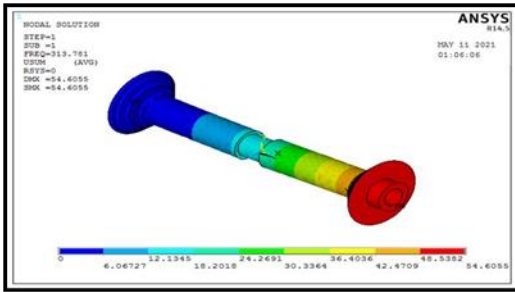

Fig.25: Mode shape of drive shaft @313.78 Hz

2) Mode shape@ 314 Hz:

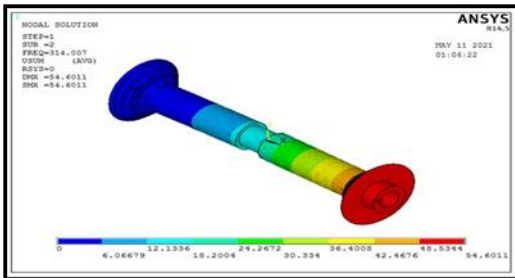

Fig.26: Mode shape of drive shaft @314Hz

3) Mode shape@ 599.66Hz:

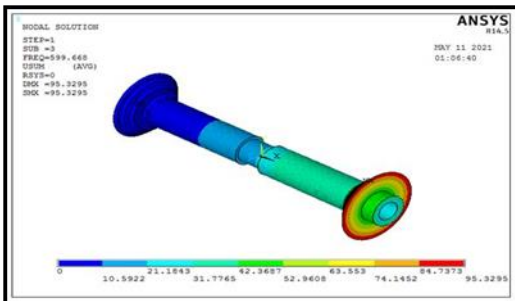

Fig.27: Mode shape of drive shaft @599.66 Hz

VI. RESULT AND CONCLUSION

Weight absorbed from model analysis results are given Bellow

MATERIAL	WEIGHT
Steel material	0.5562E-2(tons)=5.56Kg
E-Glass/Epoxy	0.1417E-2(tons)=1.41Kg
HM Carbon/Epoxy	0.11354E-2(tons)=1.13Kg

Table.4: Weight absorbed from model analysis

COST ANALYSIS:

Cost of steel =5.56 X 85=473

Cost of E-Glass epoxy =1.41 X 350 =494

Cost of HM Carbon/Epoxy =1.31 X 315 =356

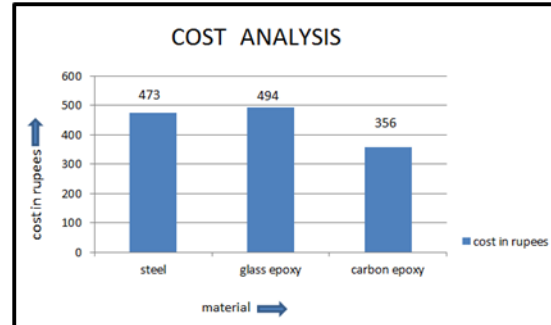

Fig 28: Graph for cost analysis

In this project, have performed

- Static analysis
- Model analysis of drive shaft by using different materials (steel, E-glass/Epoxy and HM Carbon/Epoxy) and results are tabulated below:

Results type	Steel material	E-Glass/Epoxy	HM Carbon/Epoxy
Deformation (mm)	0.0074	0.020	0.0061
Von-mises stress (MPa)	36.91	38.84	40.82
Frequency range (Hz)	178.83 – 1155.5	313.62 – 599.63	313.78 – 599.67
Mass (Kg)	5.56	1.41	1.13

Table.5: Results

From analysis results, observed that drive withstands under loading condition at all materials but here vonmises stress formed on E-Glass/Epoxy drive shaft is less compare to remaining materials. And also having less mass and frequency range. So, E-Glass/Epoxy is a best material for designed drive shaft.

- The usage of composite materials has resulted in considerable amount of weight saving in the range of 81% to 72% when compared to steel drive shaft.
- Taking into account the weight saving, deformation, shear stress induced and resultant frequency it is evident that composite has the most

encouraging properties to act as replacement to steel.

- Apart from being lightweight, the use of composites also ensures less noise and vibration.
- If we consider cost of glass/epoxy composite, it is slightly higher than steel but lesser than carbon/epoxy.
- The composite drive is safer and reliable than steel as design parameter is higher in case of composite.
- So, in comparison of mass, cost, safety and recycling steel shaft can be replaced by composite drive shaft.

- [12] M. Bharathi, Golden Kumar, Design Approach for Pitch Axis Stabilization of 3-Dof Helicopter System an LQR Controller, International Journal of Advanced Research in Electrical, Electronics and Instrumentation Engineering, ISSN 2278 - 8875, pp 351-365, Vol. 1, Issue 5, November 2012.
- [13] SRIDHAR RAJA. D, Foliated UC-EBG UWB Bandpass filter, International Journal of Advanced Research in Electrical, Electronics and Instrumentation Engineering, ISSN (Print): 2320 – 3765, pp 3701-3708, Vol. 2, Issue 8, August 2013.

REFERENCES

- [1] McEvily, A.J, “Metal Failures: Mechanisms, Analysis, Prevention”, Wiley, New York (2002), pp. 303–307.
- [2] Heyes, AM, “Automotive component failures”, Eng Fail Anal, 1998, pp.129–141.
- [3] Heisler, H, “Vehicle and engine technology”, 2nd ed, London, SAE International, 1999.
- [4] Vogwell, J, “Analysis of a vehicle wheel shaft failure”, Engineering Failure Analysis, 1998, Vol. 5, No. 4, pp. 271-277.
- [5] ASM metals handbook, “Fatigue and fracture”, vol. 19, Metals Park (OH), 1996.
- [6] Bayrakceken, H, “Failure analysis of an automobile differential pinion shaft”, Engineering Failure Analysis 13 (2006), pp. 1422–1428.
- [7] P.K. Mallick, S. Newman. Composite materials technology. Hanser Publishers. pp. 206-10, 1990.
- [8] A. R. Abu Talib, A. Ali, M. A. Badie and et al. Developing a hybrid, carbon/glass fiber-reinforced, epoxy composite automotive drive shaft. Mater. & Des. Vol. 31, 2010, pp. 514–521.
- [9] D.G. Lee, H.S. Kim, J.W. Kim, J.K. Kim. Design and manufacture of an automotive hybrid aluminum/composite drive shaft. Compos. Struct. Vol. 63, 2004, pp. 87–99.
- [10] A. Pollard. Polymer matrix composite in drive line applications. GKN technology, Wolverhampton, 1999.
- [11] P Thamarai, B Karthik, Automatic Braking and Evasive Steering for Active Pedestrian Safety, Middle-East Journal of Scientific Research 20 (10), PP 1271-1276, 2014.