

# Optimization Of Existing Power Plants in Nigeria Using Omoku Gas Plant as Case Study

DIMKPA, PRECIOUSSTONE<sup>1</sup>, D.C. IDONIBOYEGBU<sup>2</sup>, S. L. BRAIDE<sup>3</sup>

<sup>1, 2, 3</sup> Department of Electrical Engineering, Rivers State University, Port Harcourt, Nigeria

**Abstract-** Optimization of power generation of an existing power plant is a research conducted using Omoku gas turbine as a case study. The research is essential for the planning, operation, future expansion and improvement of power generation from Omoku gas turbine. The analysis was conducted to tackle and solve problem of the Omoku gas turbine that was generating power far below its total installed capacity of 150MW by improving the quality of generated power, thus optimizing the 60MW it is currently generating. The study was carried out with bus data, branch data, synchronous generator data and lump load data gotten from the staff within Omoku power station due to restricted access and Covid-19 lockdown in the country. Electrical Transient Analyser Program (ETAP) 12.6.0 was used to model and simulate the network using Fast Decoupled Load Flow Method (FDLFM). Optimal Capacity Placement (OCP) method was the improvement technique used to enhance efficiency of generated power. Simulation results show that before optimization of the network, the total active and reactive power losses realized from the network are 1428.4KW and 12161.0KVAR, respectively with average voltage drop of 3.35% along the branches of the network. Also, the auxiliary station service transformer, T7 was seen to be operated critically overloaded due to ETAP software employing the standard derating value of 37.2% on the transformer, causing it to operate below its maximum capability, thus prolonging its life span. But after Optimal Capacitor Placement (OCP), the total active and respective power losses incurred along the branches of the network were 839.4KW and 7018.0KVAR respectively. The average percentage voltage drop along the branches was also improved to 1.58%. It can also be seen from the cost analysis that a positive profit is compiled as the loss decreased saving is bigger than the operating cost for each year. A steady increase in profit over the first year of planning is observed, which thereafter

*remained constant down through the remaining years of planning, birthing and accumulative profit.*

## I. INTRODUCTION

### 1.1 Background of the Study

Generation of power in Nigeria dates back to 1886 in the colony of Lagos when two generating set were installed for community service. In 1951 and 1962, the Electricity Corporation of Nigeria (ECN) and the Niger Dams Authority (NDA) were established. The later was established for hydroelectric power development. In 1972, National Electrical Power Authority was formed from the coming together of the Electricity Corporation of Nigeria and the Niger Dams Authority. NEPA was responsible for generation, transmission and distribution of electricity. Due to power sector for reforming process in 2005, NEPA was severed and recalled Power Holding Company of Nigeria (PHCN).

In order to ensure the participation of private companies in electricity generation, transmission and distribution, the Electric Power Sector Reform (EPSR) Act was signed into law in March, 2005; thereby unbundling PHCN into six generating companies (GenCos), a transmission company (TCN) and eleven electricity distribution companies (DisCos). Nigerian Electricity Regulatory Commission (NERC) was also created by the Act as an independent regulator for the sector.

At present, it is only the transmission company that is in full control of federal government ownership. 60% of her shares in the eleven (11) DisCos has been vended to the privatized operators, while her interest has been fully deprived of her interest in the six (6) GenCos (Kayode, et al., 2018).

The generation companies that were created due to the unbundling of PHCN are Afam Power Plc (776 MW)

– 100% auctioned, Sapele Power Plc (414 MW) – 51% auctioned, Egbin – 100% auctioned and Kainji Power Plant (760 MW) – Long Term licence, Jabba Power Plant (578 MW) – Long term licence, Shiroro Power Plc (600 MW) – Long term licence.

Presently, there are 23 grid-connected generating total installed capacity of 14,242 MW (available capacity 6,136.2 MW). From this generation capacity, the thermal based generation has an installed capacity of 12,312 MW (available capacity of 4,965.7 MW), while the hydropower has 1,930 MW of total installed (available capacity of 1,325 MW). This constitutes of the privatized GenCos, Independent Power Producers (IPPs) and the generating stations under the National Integrated Power Project (NIPP). The IPPs are power plants managed by the private sector prior to the privatization process.

Optimization of power plant is often activated with improving the performance of combustion and steam processes, but supply to plant's electrical systems improvements are another prime candidate for efficiency improvements. This is better known as the electrical balance of plant (EBOP). Usually, a power plant uses up to 7% of its own electrical output to its electrical systems. Meaning in a 900 MW power plant, 63 MW of the generated electricity will be consumed by the plant's electrical system. This is actually the power that never reaches the grid. Obviously, there are ways to reduce the power loss, like installing energy efficient lighting and motion defectors. But even bigger energy savings are possible by making the plant supply to its own major electricity consumption elements and grid supply more efficient. Some of the factors influencing power generation at minimum cost are the operating efficiencies of generators, fuel cost, transmission losses, maintenance schedules, etc. (Idoniboyeobu and Ameh, 2012). In this research power loss reduction shall be thoroughly looked upon as it plays a very portentous role in the optimization of power generated. Thus, by improving the quality of generated output, electricity previously wasted can be sold to the grid, or the fuel wasted in generating can be saved. Together with local energy prices, the payback time of such a technique is typically under few years, and in some cases, just a few months.

For improvements of plants generated output in other words, supply to plant's electrical system and grid network, the load flow analysis is a very fundamental tool that gives the steady state operational values and as well enhances the best operation of the existing system for optimization. The principle information obtained from the analysis are the magnitude and phase angles at each bus, the real and reactive power flows, generator active and reactive power output and the losses along the branches of the network. Numerical methods within an acceptable tolerance are employed to obtain a solution, due to the non-linear nature of the problem (Grainger and Stevenson, 1994). The Gauss-Seidal and Newton-Raphson's method and its decoupled versions are few of the methods used in solving the non-linear system of equations.

The Fast-Decoupled Load Flow method (FDLFM) is an improved modified version of the Newton-Raphson's method. This method became reliable and widely use due to its simple calculation and fast convergence. As a result of the elaborations and efforts that have been achieved in its improvements, it's very much attractive to researchers, especially as computers and simulations are becoming more developed and are now very much involved in the analysis of large size systems. The FDLFM shall be used in the analysis of Omoku's power plant network. This research is a study on the optimization of generation from a power plant, using Omoku gas turbine as a case study. The Omoku Power Station is located at coordinates: 5o 23' 24" E, in Omoku Community, Rivers State, Nigeria. It's a simple cycle gas turbine with a total installed capacity of 150 MW (6 x 25 MW generating units) and Agip as its gas supply source. It was completed in 2005 and is currently under operation.

## II. REVIEW OF RELATED WORKS

Kadiri, et al., (2015) investigated into the reasons of power supply not being in Nigeria and proposed solutions to the problem. According to them, the problems facing the power sector in Nigeria are multidimensional and that they include: power transformers being overloaded in the grid substations, the attitude of government to management and contractors towards power generation, funds mismanagement and corruption. And that the above

factors affect the performance indices of electricity utilities in Nigeria. Based on their review, the total grid capacity as at 2015 was 7139.60 MW with 3572.6 MW (peak generation), 3091.8MW (lowest generation), 80308.49 MW (energy recorded), 49232Hz (lowest system frequency), 51.18Hz (highest system frequency), 347kv (highest voltage recorded), 300kv (lowest voltage recorded) and 3, 4907 (generation at 06.00Hrs). Solutions were proffered by them, one of which is the provision of alternative means of generation of electricity for the enhancement of increase in the stability of the electrical power problem in Nigeria. They aimed at ensuring efficient, safe and adequate production of electrical power, and also evolving stable and equitable rates which ensures reasonable profits in power sector.

Idoniboyeobu and Ameh (2012) focused on the optimization of power generation, using Afam thermal power station as a case study. They quickly highlighted some of the factors influencing power generation at minimum cost. They deduced these factors to be operating efficiencies of generators, fuel cost, transmission losses, maintenance schedules and some other physical factors. In their piece, they dwelled on minimizing operating cost while maintaining sufficient capacity, as it plays a major role in the economic scheduling of plants. They used MATLAB to develop and analyze the histogram of the fuel consumption by the station, installed capacity, fuel costing, energy generated by the station, available and actual generation for the station. The writers also talked about upgrading of the plant's switchgear for its safe reliable and efficient operation; also did they stress on rehabilitation of broken down units and increasing generational capacity.

Barinaadaa and Anthony (2015) presented an improved design of a 25MW gas turbine power plant at Omoku, Rivers State, Nigeria; with the use of combined cycle application. According to their research, it involves the reduce the total emission for the environment without hindering the performance level of the turbine by retrofitting a steam bottoming plant to the existing 25MW gas turbine plant. HMI monitoring screen, manufacturer's manual and log books were used to perform direct data collection. Modeling and simulations of the thermodynamics equation of the steam turbine plant was done using

MATLAB. According to their findings the combined cycle system possessed a total power output of 37.9MW, formed from 25.0MW from the gas turbine plant and 12.9MW from the steam turbine plant; with an HRSG, feed pump and condenser capacities of 42.46MW, 1.76MW and 29.61MW respectively. They deduced after modification that the combined cycle power plant overall efficiency was 48.8%.

Keel et al., (2011), presented a method for the evaluation of optimization efficiency in power system. Economic dispatch problems of thermal power units and unit commitment problems were the two classical optimization problems they studied. They minimized the total fuel cost and the environmental impacts in both tasks. In their research work, they showed that 30% efficiency of optimization in thermal power plants and in power system is attainable and may even go higher. The writers concluded on this note, saying that optimization power systems is of great importance as it gives the cheapest possibility of economizing on energy resources.

Peng et al., (2015) proposed a full process energy scheduling a new concept which covered annual, monthly, recently and real time full process of energy power scheduling. The writers established monthly plans range within optimization boot way and improved boot unit load rate through reasonable arrangements, and then designed annual, monthly, recently and real-time energy power scheduling plans. Introduced by the authors were the basic principles of energy saving generation dispatching, generated sorting table and implementation processes, implemented energy-solving generation dispatching optimal electric power industry structure and layout. As could be seen in the existing works above most research works associates optimization of power plant with improving the performance of combustion and steam processes as well as the use of alternative sources to reduce the cost of production. These existing works do not demonstrate the improvement of the electrical balance of the plant by increasing the power factor of the plant as a prime candidate for efficiency improvement.

### III. MATERIALS AND METHODS

#### 3.1 Materials Required for Network Analysis

Required data for analysis and simulation of the Omoku gas turbine station shall be bus data, Branch data, synchronous generator data, Lump Load data and Electrical Transient Analyzer Program (ETAP) 12.6.0 software. The network under study shall be analyzed using the Fast Decoupled Load Flow Method (FDLM) algorithm, as embedded in ETAP 12.6.0. Optimal capacitor placement method shall be the optimization technique used, after which the objective function of the techniques shall be taken into consideration.

#### 3.2 Fast-Decoupled Load Flow Method Used

The FDLM is an improved modification of the Newton-Raphson method. It is based on the fact that a small change in bus voltage magnitude and phase angle does not change appreciably the active power and reactive power respectively. Hence the flow equation gotten from the Newton-Raphson method can be modified into two different decoupled sets of load flow equations. These are then solved iteratively.

$$\begin{aligned} [\Delta P] &= [J_1] [\Delta \delta] \\ [\Delta Q] &= [J_4] [\Delta V] \end{aligned}$$

The FDLM offers a less computational time than as required by the Newton-Raphson method, since the Jacobian matrices are constant. It also reduces computer memory storage by approximately half as compared to the Newton-Raphson method. Its convergence criterion is centered on active and reactive power mismatches, and is typically set to 0.001 in the order of MW and MVAR. In general, the FDLM is at a preference, especially when the Newton-Raphson method fails in dealings with long radical systems or systems having long transmission lines or cables.

#### 3.3 Optimal Capacitor Placement (OCP)

The OCP genetic algorithm is an improvement technique that is centered on the natural selection theory. The objective function of OCP is to minimize the cost of the system, which is determined in four ways:

The fixed capacitor installation cost

Capacitor purchase cost

Capacitor bank operating cost (maintenance and depreciation)

Cost of real power losses

This is mathematically interpreted as:

$$\text{Min objective function} = \sum_{i=1}^{N_{bus}} (X_i C_{oi} + Q_{ci} C_{li} + B_i C_{2i} T) + C_2 \sum_{l=1}^{N_{load}} T_l P_L^l$$

$N_{bus}$  =Number of bus candidates

$X_i$  =0/1, 0 means no capacitor placed at bus i

$C_{oi}$  =Installation cost

$C_{li}$  =Per KVAR cost of capacitor banks

$Q_{ci}$  =Capacitor bank size in KVAR

$B_i$  =Number of capacitor banks

$C_{2i}$  =Operating cost of per bank, per year

$T$  =Planning period (years)

$C_2$  =Cost of each KWh loss, in \$/KWh

$L$  =Load levels, maximum, average and minimum

$T_l$  =Time(hours), of load level  $l$

$P_L^l$  =Total system loss at load level  $l$

#### 3.4 Power in Balance 3-Phase System

The apparent power per phase is represented as

$$\bar{S}_{1\phi} = \bar{V}_{LN} \bar{I}^*$$

$$\bar{S}_{3\phi} = 3 \times \bar{S}_{1\phi}$$

$$= \sqrt{3} \times \bar{V}_{LL} \bar{I}^*$$

$$= P + jQ$$

#### 3.5 Load Calculation

Apparent power in kilo rating is represented as

$$KVA = \sqrt{(KW)^2 + (KVar)^2}$$

$$PF = \frac{KW}{KVA} I_{3\phi} = \frac{KVA}{(\sqrt{3} \times KV)}$$

$$I_{i\phi} = \frac{KVA}{KV}$$

#### 3.6 3-Phase Per Unit System

##### 3.6.1 3-Phase Power Equation

Apparent power and voltage in a 3-phase system can be illustrated as

$$S = \sqrt{3} VI$$

$$V = \sqrt{3} ZI$$

### 3.6.2 Base Calculation

The base current and the base impedance are given as

$$I_B = \frac{KVA_B}{\sqrt{3} KV_B}$$

$$Z_B = \frac{(KVA_B)}{MVA_B}$$

### 3.6.2 Per Unit Calculations Bus Voltage

The per unit quantities are illustrated as

$$I_{pu} = \frac{I_{actual}}{I_B} \quad V_{pu} = \frac{V_{actual}}{V_B}$$

$$Z_{pu} = \frac{Z_{actual}}{Z_B} \quad S_{pu} = \frac{S_{actual}}{S_B}$$

$$Z_{pu}^n = Z_{pu}^o \left[ \frac{V_B^o}{V_B^n} \right] \left[ \frac{S_B^k}{S_B^o} \right]$$

“n” stands for new values and “o” stands for old values

### 3.6.3 Base Voltage

The base voltage at any point of the network is formed in respect to the transformer turns ratio.

$$KV_B^1 = \frac{N_1}{N_2} KV_B^2$$

### 3.6.5 Impedance of Transformer in Per Unit

The per-unit impedance of a transformer is represented as

$$X_{pu} = \frac{X_{pv} \times \left[ \frac{X}{R} \right]}{\sqrt{1 + \left[ \frac{X}{R} \right]^2}}$$

$$R_{pu} = \frac{X_{pv}}{\left[ \frac{X}{R} \right]}$$

### 3.7 Percentage Voltage Drop

The voltage drop along the network is given as

$$V_D = V_S - V_R$$

$$V_D = I_R^2 + I_X X$$

$$\%V_D = \frac{V_D}{V_S} 100$$

### 3.8 Shunt Capacitors

Shunt capacitors are strategically installed in the system to inject the much needed VAR by inductive loads. This action thus reduces the apparent power flow from supply source and in turn reduces the line current flow. Hence, the reduction of losses ( $I^2R$ ) and increase in voltage profile and of course the power factor of the network.

Assume an initial apparent flow of  $S_1$ , having real and reactive power of  $P_n$  and  $Q_1$  respectively. Thus;

$$S_1 = [P_1^2 + Q_1^2]^{\frac{1}{2}}$$

When shunt compensator is installed, thereby injecting reactive power of  $Q_c$ , the new apparent power becomes  $S_2$ ;

$$S_2 = [P_1^2 + Q_1^2]^{\frac{1}{2}}$$

$$S_2 = [P_1^2 + (Q_1 - Q_c)^2]^{\frac{1}{2}}$$

### 3.9 Power Factor Correction

If  $S_1$  is the existing apparent power supply, then the existing power factor ( $PF_1$ ) will thus be:

$$PF_1 = \cos \theta = \frac{P_1}{[P_1^2 + Q_1^2]^{\frac{1}{2}}}$$

When a shunt capacitor of  $Q_c$  is strategically installed, the new power factor ( $PF_2$ ) will be:

$$PF_2 = \cos \theta_2 = \frac{P_1}{[P_1^2 + (Q_1 - Q_c)^2]^{\frac{1}{2}}}$$

hence the increase in power factor.

### 3.9 Power Factor Improvement Calculation

The power triangle which is a phasor representation of the three kinds of electrical power is as shown below.

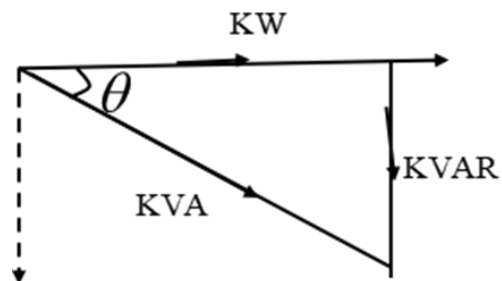

Figure 3.1: The Power Triangle

$$PF = \cos \theta = \frac{KW}{KVA}$$

$$T \tan \theta = \frac{KVAR}{KW}$$

$$KVar = KW \times \tan \theta$$

If the reactive component of the power at the existing power factor is  $KW \times \tan \theta_1$  and likewise at an improved power factor is  $KW \times \tan \theta_2$ , since the real power component (KW) remains constant for a given load irrespective of the change in PF (KVA and KVAR changing with PF), the capacitor required to improve the power factor will be:

$$cK var = KW \tan \theta_1 - KW \tan \theta_2 \quad (3.32)$$

$$cK var = KW(\tan \theta_1 - \tan \theta_2)$$

$cK var = KW \times \Delta \tan \theta$  is called the KW multiplier or correction factor (Jude, *et al.*, 2019)

#### IV. RESULTS AND DISCUSSION

##### 4.1 Results

The outcome of the power flow analysis was obtained using the Fast Decoupled Load Flow Method (FDLFM) in the ETAP 12.6.0 program. The technique used for optimization of the Omoku gas turbine network is the Optimal Capacitor Placement (OCP) algorithm, embedded in the ETAP 12.6.0 program. See the appendix for different results sections of the methods adopted and the simulation of the network.

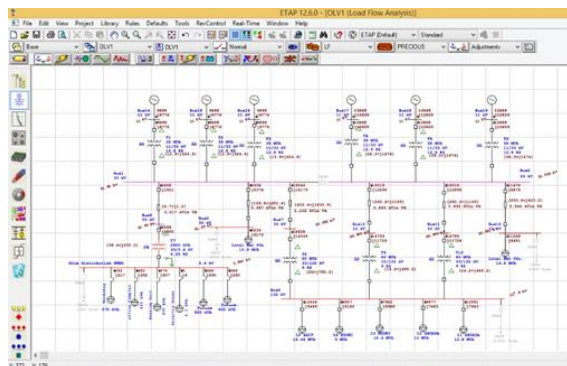

Figure 4.1: Load Flow Analysis of Omoku Gas Turbine before Optimization

Figure 4.1 presents the results after the simulation of the modeled network. It is seen from the complete alert report on the appendix that Buses 5, 7, 8, 10, 11,

12 and SWBD were flagged critical under voltage. While Buses 1, 2 and 5 were flagged marginal under voltage. Also, from simulations, it is seen that the power factor of the network was approximately 80% which accounts for the degree of losses incurred by the system. Since power factor of a system tells of the quality of power generated and transmitted into the buses and along the branches and that system, a network's PF of 0.8 means there will be large reactive power injected into the system. Hence, the huge losses and drops incurred by the network along its branches (due to I<sup>2</sup>R), giving rise to the reduction of the voltage profile of the network's buses. The total losses realized from the network are 1428.4kw active power, 12161.0KVAR reactive power and an average percentage voltage drop of 3.35% along the branches of the network. Finally, from figure 4.1, the distribution transformer 77 was seen to be flagged critically overloaded, even though the total lump load hung on it was not up to its capacity. This is so because ETAP software uses the standard iterating value of 37.2% causing the transformers to operate at less than their maximum capacity in order to prolong their life span.

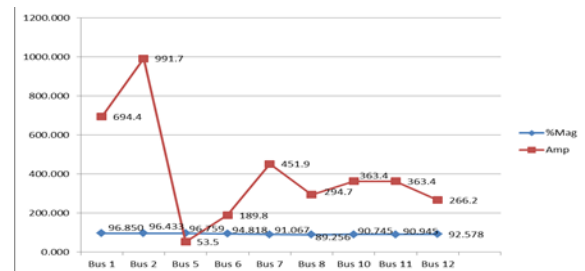

Figure 4.2: Bus Voltage and Current Flow at Buses before Optimization

Figure 4.2 above shows the voltage profile and current flow at the buses before improvements was carried out on the network. The blue curve depicts the percentage magnitude of the voltage at each respective buses, while the red curve gives the flow of current into the corresponding buses. The corresponding buses.

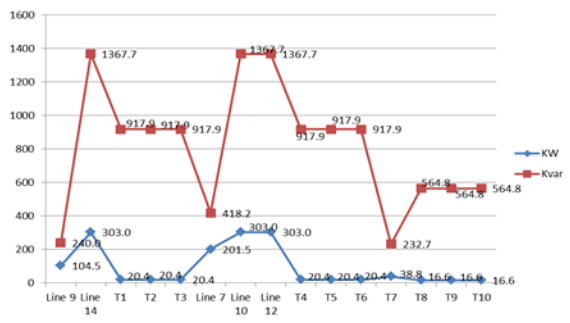
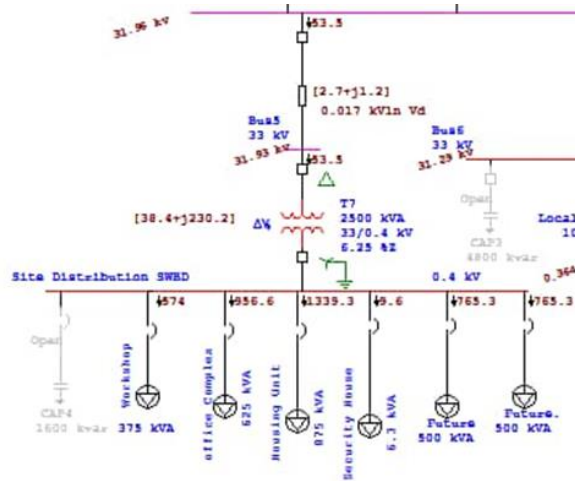

Figure 4.3: Branch Losses Summary Report before Optimization

Figure 4.3 reveals the losses at corresponding branches before capacitors were strategically placed to improve the network. The blue curve gives the active losses in KW at the respective branches of the network. The curve in red shows the reactive losses in KVAR at same corresponding branches of the network.

4.2 Load Flow Analysis of a Section of Omoku Gas Turbine Network



4.4: Figure Cut Section of Omoku Gas Turbine Network

4.2.1 Load Drawn into the above Section

Current injected from Bus 1

$$= \frac{\text{Total sum of lumped loads (KVA)}}{\sqrt{3} \times 31 \cdot \text{KV}_{\text{Bus1-actual}}}$$

$$= \frac{2881 \cdot 3 \text{KVA}}{\sqrt{3} \times 31 \cdot 731 \text{KV}}$$

Branch impedance (Z) from ETAP 12.6.0 library impedance

$$= 0.3531 \Omega$$

$$\text{Voltage drop along cable} = 52 \cdot 43 \times 0 \cdot 35231 = 0.018 \text{KV}$$

V<sub>Bus- actual</sub>

$$= 31 \cdot 73 \text{KV} - 0 \cdot 018 \text{KV}$$

$$= 31 \cdot 71 \text{KV}$$

$$\text{Current injected by Bus 5} = \frac{\sum \text{Lumped Loads}}{\sqrt{3} \times \text{KV}_{\text{Bus5-actual}}}$$

$$= \frac{2881 \cdot 3 \text{KVA}}{\sqrt{3} \times 31 \cdot 71 \text{KV}}$$

$$= 52 \cdot 46 \text{A}$$

Impedance of transformer (T7) = 0.0625Ω

$$\text{Drop along transformer} = 52 \cdot 46 \times 0 \cdot 0625 = 0 \cdot 003 \text{KV}$$

Primary voltage of T7

$$= 31 \cdot 71 \text{KV} - 0 \cdot 003 \text{KV}$$

$$= 31 \cdot 707 \text{KV}$$

$$= \frac{0 \cdot 4}{33} \times 31 \cdot 707 \text{KV}$$

Secondary voltage of T&

$$= 0 \cdot 384 \text{KV}$$

$$= \frac{6 \cdot 3 \text{KVA}}{\sqrt{3} \times 0 \cdot 84 \text{KV}}$$

Load drawn by security house

$$= 9 \cdot 5 \text{Amps}$$

4.2.2 Size of Capacitor Required to improve PF to 0.95

Strategically, capacitor bank shall be installed at site distribution switch board to provide the needed KVAR by the Lump Leads.

$$\text{Total size of lump load on bus} = 2881 \cdot 3 \text{KVA} \times 0 \cdot 8$$

$$= 2305 \cdot 04 \text{KW}$$

Desired Power factor = 0.95

$$\text{Required size of capacitor} = \text{KW} \times s \tan \theta$$

From the power factor correction table, the KW multiplier corresponding to 95% desired power factor under an existing power factor of 80% is 0.421



Hence, size of capacitor needed

$$= 2305 \cdot 04 \times 0 \cdot 421$$

$$CKVar = 970 \cdot 42 \text{ KVAR}$$

800KVAR size of capacitor bank shall be employed in the entirety of this research. Thus, for uniformity, 2 x 800KVAR size of capacitor bank shall be installed at site distribution switch board bus for the needed compensation.

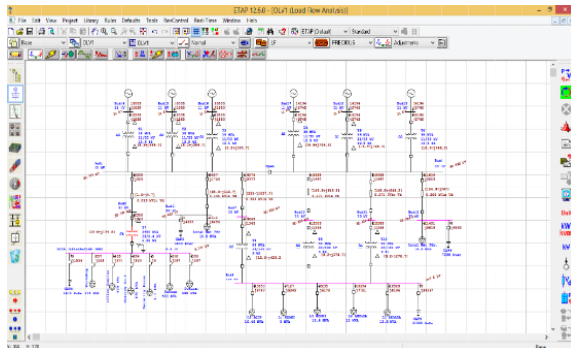

Figure 4.5: Load Flow Analysis of Omoku Gas Turbine after Optimization

Figure 4.5 above shows the result of simulation of the Omoku gas turbine network after optimally placing the required capacitors at strategic locations for optimization. The complete alert report in the appendix showed the drastic improvements of the voltage profile of the Buses; with Buses 7, 8, 10, 11, 12 and SWBD only now flagged marginal critical. From the result, it is seen that substation power factor has been drastically improved to approximately 95%. Thus, the quality of power generated and transmitted has been improved; which accounts for the reduction of power losses (due to I<sup>2</sup>R) and voltage drops along the branches of the network. After OCP, the total power losses incurred along the branches of the network were 839.4KW active power and 7018.0KVAR reactive power. While the average percentage voltage drop along the branches was 1.58%, indicating a significant improvement of the network.

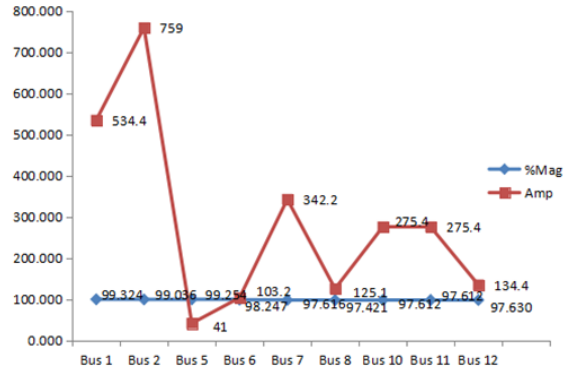

Figure 4.6: Bus Voltage and Current Flow at Buses after Optimization

Figure 4.6 above depicts the voltage at the buses of the network, as well as the flow of current into the corresponding bus of the network, after carrying out the improvement technique of Optimal Capacitor Placement. As seen from the graph, the blue curve gives the voltage profile of the respective buses, while red curve shows the flow of current into those buses after optimization.

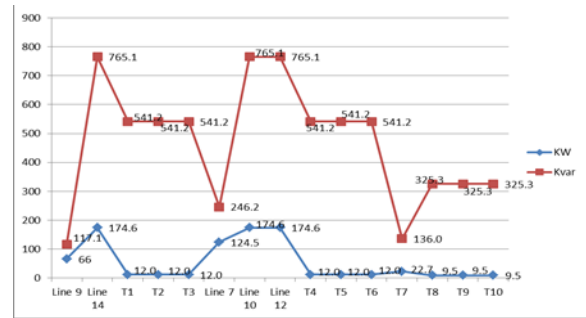

Figure 4.7: Branch Losses Summary Report after Optimization

Figure 4.7 gives the losses at the branches of the network after sizing and strategically placing capacitors in the network, so as to improve the quality of electricity generated and delivered. The blue curve gives the real losses along the respective branches of the network and the red curve shows the reactive losses along corresponding branches of the network after improvement method.



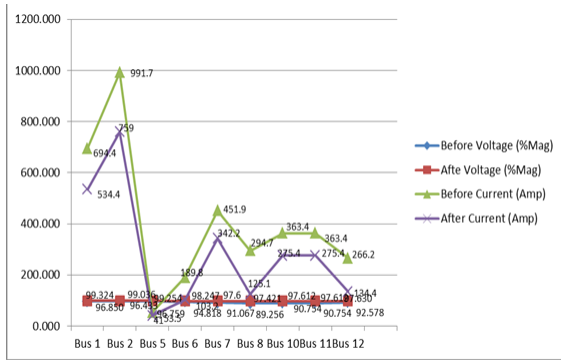

Figure 4.8: Comparing Results of Voltage Profile and Current Flow for before and after

Optimization

Figure 4.8 shows the difference in results of bus voltage profile and current flow into buses before and after improvement technique was done on this network. The blue curve shows the voltage profile of the buses before optimization, while the red curve gives the profile of buses after improvement. The lemon and purple curves shows the flow of current into the buses, before and after optimization respectively. Notice the slight increase of the values of the voltage profile of each bus from before to after optimization. And also notice the reduction of flow of current into each bus from the supply. This is so because, after optimization, part of the current need by the inductive loads of the network are supplied by the shut capacitors. Thus, current drawn from the supply becomes reduced. Hence, the reduction in losses and increase in the voltage profile of buses.

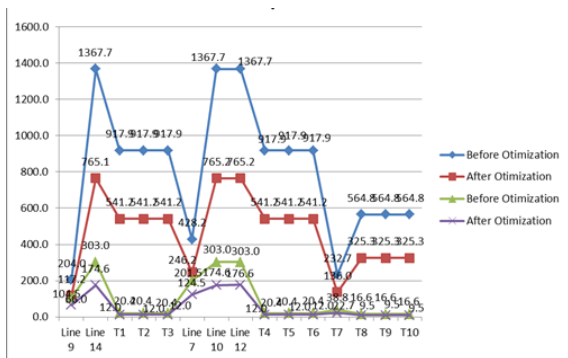

Figure 4.9: Comparing Branch Losses Report for before and after Optimization

Figure 4.9 above shows the difference in power losses along the branches of the network, before and after

improvement technique was done. The blue curve gives the amount of reactive losses along the branches before improvement technique. The red curve indicates reactive losses along the branches before optimization. The lemon and purple curves shows the amount of real power losses along the branches of the network before and after the improvement technique respectively. Notice the decrease in value of both the active and reactive power loss along corresponding branches of the network. As earlier stated, it is as a result of the installed capacitors injecting required VAR to the system, thus bringing about reduction in VAR drawn from supply. As a result of this, power (due to 12R) along the branches is reduced.

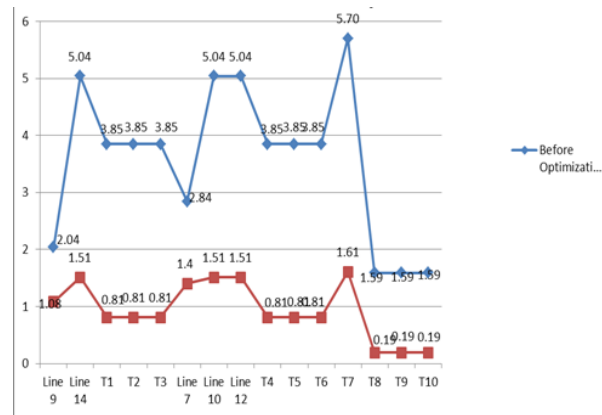

Figure 4.10 Comparing Results of Percentage Voltage Drop of before and after Optimization

The graph above shows the results of drops in percentage voltage before and after Optimal Capacitor Placement technique. The blue curve gives the results of voltage drop along the branches of the network before optimization, while the red curve gives the drops along branches after optimization. Notice the significant drop in voltage loss along corresponding branches. This happens due to loss reactive current (power) drawn from supply, thus bringing about a reduction in voltage drop along the branches.

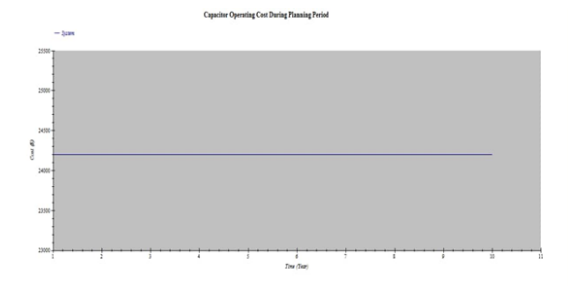

Figure 4.11: Capacitor Operating Cost during Planning Period

The plot shows the operating cost in dollars against the time in years of operation. It is seen from the plot that the operational cost remains the same for over a planning period of 10 years.

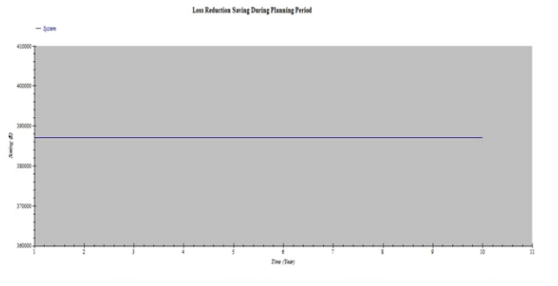

Figure 4.12: Loss Reduction Saving during Planning Period

This plot presents the savings incurred against the time in a 10 years planning period. As seen from the plot, the loss reduction of \$387089.60 remains constant all through the 10 years planning period.

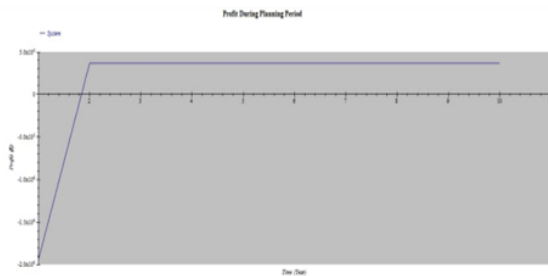

Figure 4.13: Profit during Planning Period

The plot gives the profit against a 10 years' period of planning. The savings realized each year will be used to pay off the operating cost and installation cost. Any unpaid money is expressed as fixed cost for the following year. A positive profit can be compiled when the loss decreased saving is bigger than the operating cost for each year. As can be seen from the plot, there's a steady increase in profit over the first year of planning, which thereafter remained same all through the remaining 9 years of planning, giving rise to an accumulative profit.

## CONCLUSION

The research on optimization of power generation on existing power plant using Omoku gas turbine as a case study was done by collecting appropriate data from field survey of the power plant and analyzing the network under study using Fast Decoupled Load Flow technique, thereafter, using OCP to optimize the power output from Omoku gas turbine, thus improving the quality of its generated power; so that for the same apparent power generated more real power load can be accommodated. Simulation results from the proposed technique of analysis showed several of the buses to be operated critically under voltage with the system operating at a power factor of about 0.8; thus, incurring huge losses and drops along the branches of the network.

Before optimization technique was carried out on the network, the total active and reactive power losses were 1428.4 KW and 12161.0 KVAR respectively, with an average percentage voltage drop of 3.35%. It was also seen that the auxiliary station service transformer T7 was operating critically. Despite the transformer loading been lesser than the capacitor of the auxiliary transformer. As explained in chapter four, ETAP software uses the standard derating value of 37.2%, hence, the transformer tends to operate at less than its maximum capability, thus creating an allowance and prolonging its life span.

The introduction of the improvement method gave rise to an improved power factor, which automatically improved the quality of power generated and transmitted for consumption. Hence, the reduction in power losses and voltage drop is along the branches of the network. Simulation results shows that after optimally placing of capacitors at strategic locations of the network, the total power active and reactive losses amounted to 839.4KW and 7018.0KVAR, with an average percentage voltage drop along the network's branches of 1.58. So for the same apparent power injected into the system, more active power load can be accommodated, thereby releasing substation capacity.

The cost analysis after optimization shows that the capacitor operating cost and loss decreased saving during planning period remains constant all through

the planning period (10 years). Therefore, the savings gotten every year will be used to offset the operating and installation cost. Any money left will be taken as fixed cost for the following year. A positive profit can be compiled when the loss decreased saving is bigger than the operating cost for each year. And from simulation results, there is a steady increase in profit over the first year of planning, and remained constant for the remaining years, giving rise to an accumulative profit.

## 5.2 Recommendations

With results from the analysis of Omoku gas turbine network, I hereby recommend that:

An appropriately sized transformer with a capacity greater than the existing auxiliary transformer T7 should be used, so as to accommodate for allowance (standard derating value of 37.2%).

Proper inspection and maintenance should be carried out on the system to correct all weak insulators and hot spots.

Appropriately sized capacitors should be kept at strategic locations to enhance the quality of power generated.

## ACKNOWLEDGMENT

My profound gratitude goes to God Almighty for His Love, mercies and wisdom throughout my years of studies.

My special thanks goes to my supervisors Prof. D. C. Idoniboyeobu and Dr. S. L. Braide for their academic guidance.

My thanks goes to Prof. C. O. Ahiakwo, Dr. S. Orike, Dr. I. Okara, Engr. L. Boma, the staff of the department of electrical engineering and every member of the faculty of engineering for their support in my academic growth.

Finally, my appreciation goes to my parents (Mr. and Mrs.) Dimkpa for supports and prayers towards my success and course mates who have been there with me all the time.

## REFERENCES

- [1] Barinaadaa, T. L. & Anthony, K. L. (2015). Improved design of a 25MW Gas Turbine Plant Using Combined Cycle Application. *Journal of Power and Energy Engineering*, 3, 1-14.
- [2] Bestman, U. O., Victor, C. I. & Biobele, A. W. (2019). Power factor correction in Iwofe Injection substation; Impact on the distribution Network. *American Journal of Engineering Research (AJER)*, 8(10), 186-195.
- [3] Cengel, Yunus A., Michael A & Boles (2011). *Thermodynamics: An Engineering Approach*. 7th Ed. New York: McGraw-Hill.
- [4] Chimwuko, E. C., Mgbemena, Chimedum, O., Aguh, P., Ebhota & Williams, S. (2011). Electricity generation and distribution in Nigeria. Technical issues and solutions. *International Journal of Engineering Science and Technology (IJEST)*; 3(11), 7934-7941.
- [5] Glamami, M., Fayazi, B. A. & Behbahami, S. (2016). Performance Optimization of a Gas Turbine Power Plant Based on Energy and Exergy Analysis. *Mechanics, Materials Science & Engineering*; 2412-5954, 29-41.
- [6] Guarnieri, (2013). The Beginning of Electric Energy Transmission Part One. *IEEE Industrial Electrics Magazine*, 7 (1), 57-60.
- [7] Harpreet, K. C. (2017). Overview of power factor improvement techniques. *International Journal of Research in Engineering and Applied Science*, 7(5), 27-36.
- [8] Idoniboyeobu, D. C. & Ameh, P. S. (2012). Optimisation of power generation: A case study of Afam thermal power station, Rivers State, Nigeria. *International Journal of Academic Research*, 4(2).
- [9] Idoniboyeobu, D. C. Kingmate, E. & Wokoma, B. A. (2018). Improvement of electric power supply to Port Harcourt Refining Company, Rivers State, Nigeria. *International Journal of Scientific & Engineering Research*, 9(3), 2229-5518.
- [10] Igunbor, I. A., Atuchukwu, A. J. & Iloh, J. P. I. (2019). Optimal capacitor placement technique for optimization of power distribution networks

- in Nigeria. *Iconic Research and Engineering Journals*, 3(2), 2456-8880.
- [11] Jude, D. A., Idoniboyeobu, D. C. & Braide, S. L. (2019). Development of an improved electrical power distribution of Old Port Harcourt Township. *American Journal of Engineering Research (AJER)*, 8(7), 32-40.
- [12] Kadiri, K. O., Alimi, M. O. & Alabi, A. O. (2015). Ways of achieving stable and uninterrupted power supply of electricity in Nigeria. *British Journal of Applied Science & Technology*. 10(5), 1-15.
- [13] Kayode, O., Agbetuyi A. F., Owolabi, B., Obiakor, Chukwuemeka, F. O., (2018). Power Sector Reform in Nigeria: Challenges and solutions. *IOP conf. Series: Materials Science and Engineering*. 413(2018)012037. doi:10.1088/1757-899x/413/1/012037.
- [14] Keel, M., Medvedeva-Tsernobrivaja, V., Shuvatora, J., Tammoja, H. & Valdina, M. (2011). On Efficient of Optimisation in Power System. *Oil Shale*, 28(15), 253-261. doi:10.3176/oil.2011.15.16.
- [15] Optimising Power Plant Performance for Energy Efficiency. <https://www.abb-conversions.com/2013/08/optimizing-power-plant-performan-for-energy-efficiency/>
- [16] Patricia, A. & David, A. (2016). Thermoelectric Power generation optimization by thermal design means. Retrieved from <http://dx.doi.org/10.5772/65849>.
- [17] Paul, B. (2005). *Power Generation Technologies*. Newness. 59. ISBN 9780080480107.
- [18] Peng, W., Chunsheng, W., Yukun, H., Liz, V. & Wei, W. (2018). Power Generation Expansion Optimization Model Considering Multi-Scenario Electricity Demand Constraints: A case study of Zhejiang Province, China. *Energies*, 11, 1498; doi:10.3390/en11061498.
- [19] Peng-fei, L., Qun-tai, S & Qui-feng, C. (2015). Optimization of power plant generating capacity scheduling based on Markor model. *The Open Electrical & Electronic Engineering Journal*, 9, 610-616.
- [20] Seifid, S. S. S. G., Mousavi, S. M. H. & Mirbragheri, S. M. (2015). Improving the transient states caused by switching of capacitor banks in power dispatching stations. *Walailak Journal Science & technology*; 12(4), 343-360.
- [21] Suzan, A., Ahmed, O., Ahmed, S. & Mahmoud, E. (2017). A real-time optimization of reactive power for an intelligent system using genetic algorithm. *Preparation of papers for IEEE ACCESS*, 20. Doi:10.1109/ACCESS.2020.2965321, IEEE ACCESS.
- [22] Uchegbulum, O., Opeh, R. N. & Atenaga, M. O. (2014). Assessment of power generation resources in Nigeria. *IOSR Journal of Applied Physics (IOSR-JAP)*, 6(2), 44-50.