

Voltage Stability Improvement in Power System Using STATCOM and SVC

D. C. OYIOGU¹, DR. V. C. OGBOH², N.A. NWOYE³

^{1, 2, 3} Department of Electrical Engineering, Nnamdi Azikiwe University, Awka

Abstract- Flexible AC Transmission System (FACTS) devices such as Static Var Compensator (SVC) and Static Synchronous Compensator (STATCOM) when placed at the midpoint of a long transmission line play an important role in controlling the reactive power flow into the power network. This Thesis explores the effect of STATCOM and SVC on voltage stability. The Nigerian 24-bus system has been used to demonstrate the ability of STATCOM and SVC in improving the voltage stability of a power system network. The structure of STATCOM and SVC are explained and their impact on midpoint voltage regulation. Furthermore, the performance of the STATCOM is compared with that of conventional static var compensator (SVC). Newton Raphson load flow analysis was carried out on the Nigerian 24-bus 330KV network using Neplan Engineering software. It was discovered that STATCOM provided a high reactive power support than SVC and also improved the static voltage of the buses to which it was connected to, as well as other buses that were not directly connected to the STATCOM. Although SVC improved the voltages of the buses to which it was connected to as well as other buses not directly connected to it, STATCOM displayed a greater improvement of the bus voltages to which it was connected to, with STATCOM offering the highest voltage improvement of 1.0388pu while SVC offered an improvement of 1.0282pu. The real and reactive power losses in the system network were reduced when STATCOM and SVC were inserted into the network, however the real and reactive power losses were lower when STATCOM was inserted than when SVC was inserted with STATCOM having a reactive power loss of 467.2285MVar giving a total reduction of 32.01% in the reactive power loss of the network while SVC had a total reactive power loss of 481.4609MVar giving a total reduction of 29.94% in the reactive power loss in the network. Similarly, STATCOM had an active power loss of 53.8229MW

giving a total reduction of 17.96% in the active power loss of the network while SVC had an active power loss of 54.2594MW giving a total reduction of 17.30% in the active power loss of the network.

Indexed Terms- Fact devices, Load Flow, Power system stability Reactive Power

I. INTRODUCTION

Power system stability is the ability of a power system which enables it to remain in a stable operating equilibrium under normal conditions and to return to a stable state after it has been subjected to some form of disturbance.[1]. A power system becomes unstable when voltages uncontrollably decrease due to outage of Generators, sudden increment in load. [2] One of the major reasons for voltage instability is reactive power imbalance in the system. This affects the load ability of a bus in a power network.

When the load increases, there will be a corresponding decrease of the voltage at the bus. Continuous increase in the loading of the network results in shortage of reactive power. Thereafter, if the active and reactive power increases, there will be a quick decrease in the voltage magnitude at the bus. As critical point is reached, heavy reactive power losses lead to a high voltage drop which consequently leads to voltage collapse. Power electronic based equipment such as FACTS (Flexible AC Transmission System) controllers with their ability to rapidly respond to system events and improve the quality of power delivered constitutes one of the technical advancements which address the operating challenges that are being presented today. Among the FACTS controllers, the one that is most advanced is the one that employs voltage sourced converter (VSC) as synchronous sources. Static Synchronous Compensator (STATCOM) is a voltage source inverter which converts a D.C input voltage into A.C

output voltage so as to compensate for the reactive and active power required by the system. [3] FACTS devices- Static Var Compensator (SVC) and STATCOM can provide reactive power support. SVCs are known to improve the properties of a power system like voltage regulation, stability limits, dynamic over voltage and under voltage control as well as var compensation. STATCOM is purely a voltage source converter (VSC) which converts a D.C voltage to a three phase A.C voltage at a fundamental frequency of controlled magnitude and phase angle. VSCs use pulse width modulation technology which makes it capable of providing high quality ac output voltage to the grid or even to a passive load. STATCOM is used for shunt compensation in the same manner as SVC. However, it utilizes a voltage source converter in place of shunt capacitors and reactors. The main principle in the operation of a STATCOM is that it generates a controllable A.C voltage source through a leakage transformer by a voltage source converter which is connected to a D.C capacitor. The difference in the voltage across the leakage reactance is utilized in the production of reactive and active power exchange between the STATCOM and the power system.

II. METHODOLOGY

The Newton Raphson’s Load flow analysis method is used in this work. A NEPLAN based program was developed for the power flow analysis of the 24-bus Nigerian 330kV system without Facts and with STATCOM and SVC.

This Neplan Engineering Software is one of the most complete planning, optimization and simulation tool for transmission, distribution, generation and industrial networks. It is a software program made from Swiss that is widely used for the purpose of planning and information systems on the network of electrical gas and water. It also provides all the menus and calculation modules, making it easy to operate by the user.

To obtain the power flow equation, we need to consider the diagram of a typical bus of the power system in fig 1

Application of KCL to the bus results in

$$I_1 = y_{i0}V_i + y_{i1}(V_i - V_1) + y_{i2}(V_i - V_2) + \dots + y_{in}(V_i - V_n)$$

$$I_1 = (y_{i0} + y_{i1} + y_{i2} + \dots + y_{in})V_i - y_{i1}V_1 - y_{i2}V_2 - \dots - y_{in}V_n \tag{1}$$

$$\Rightarrow I_1 = V_i \sum_{j=0}^n y_{ij} - \sum_{j=1}^n y_{ij}V_j \quad j \neq I \tag{2}$$

Where I_1 = current in bus 1

V_i = voltage at bus i

V_1 = voltage at bus 1

V_2 = voltage at bus 2

y_{ij} = bus admittance matrix from bus i to j

Therefore the real and reactive power at bus I is given by

$$P_i + JQ_i = V_i I_1^*$$

Where P_i = The real power

JQ_i = The reactive power

Thus substituting for I in (2) above we obtain

$$P_i + JQ_i = V_i^* [V_i \sum_{j=0}^n y_{ij} - \sum_{j=1}^n y_{ij}V_j] \quad j \neq I \tag{3}$$

This equation is used in calculating the real and reactive power of the slack bus. Therefore assuming a three bus system, the equation becomes

$$P_i + JQ_i = V_i^* [V_i (y_{i2} + y_{i3}) - (y_{i2}V_2 + y_{i3}V_3)] \tag{4}$$

Where V_1 = voltage at bus 1

V_2 = voltage at bus 2

y_{12} = bus admittance matrix from bus 1 to bus 2

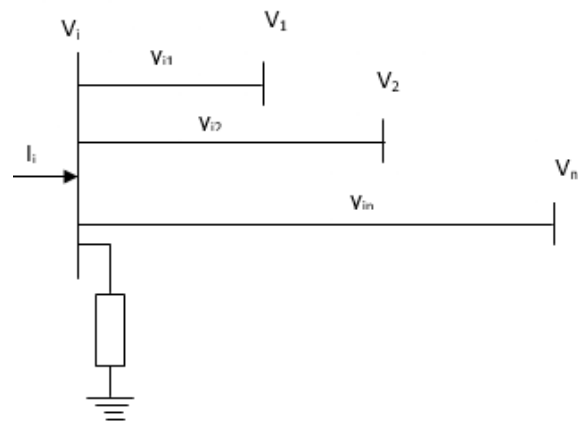

Figure 1 A typical bus of the power system

Similarly to obtain the equation for the line flows, we need to consider the diagram of fig 2

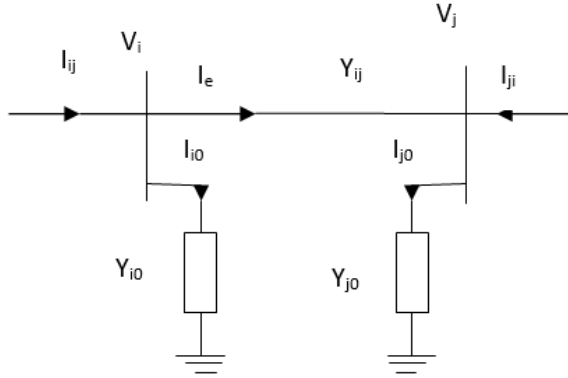

fig 2: Transmission line model for line flow

Considering the line connecting the two buses i and j, the line current

I_{ij} measured at bus i and defined positive in the direction $i \rightarrow j$ is given by

$$I_{ij} = I_e + I_{i0} = y_{ij}(V_i - V_j) + y_{i0}V_i \quad (5)$$

Similarly the line current I_{ji} measured at bus j and defined positive in the direction $j \rightarrow i$ is given by

$$I_{ji} = -I_e + I_{j0} = y_{ij}(V_j - V_i) + y_{j0}V_j \quad (6)$$

Thus the complex powers S_{ij} from bus i to j and S_{ji} from bus j to i are

$$S_{ij} = V_i I_{ij}^* \quad (7)$$

$$S_{ji} = V_j I_{ji}^* \quad (8)$$

Where I_{ij} = current moving from bus i to j

V_i = voltage at bus i

V_j = voltage at bus j

y_{ij} = bus admittance matrix from bus i to j

y_{j0} = bus admittance matrix from bus j to 0

S_{ji} = complex power from j to i

S_{ij} = complex power from bus i to j

Nigeria 330kV 24 bus transmission network

The test system is the Nigerian 330kV 24-bus network and the diagram is shown in fig 3 below. Fig 3

represents the test system. The test system consists of seven generating stations and Seventeen Load stations which are divided into three major sections as North, South-East and South-West. The North is connected to the South through one triple circuit line between jebba and Oshogbo while the West is linked to the East through one transmission line from Oshogbo to Benin and one double circuit line from Ikeja to Benin

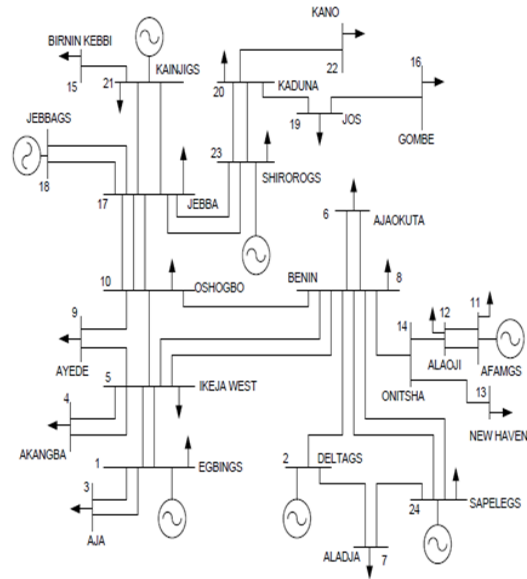

Figure 3: The 24-bus 330kV Nigerian Transmission System Network

Implementation

A NEPLAN based program was developed for the power flow analysis of the 24-bus Nigerian 330kV system without Facts and with STATCOM and SVC. The input data includes the basic system data needed for conventional power flow calculations which are the bus data, the transmission line data, generation and load data and the values of these data are given in the tables below.

Table I: Transmission line data of the Nigerian 24- bus network

From Bus	To Bus	Length (Km)	Resistance R (Ohm/Km)	Reactance X(Ohm/Km)	Susceptance B (Ohm/Km)
1 Egbin	3 Aja	14	0.00155	0.0172	0.2570
1 Egbin	5 Ikj West	62	0.00155	0.0172	0.2570
2 Delta	7 Aladija	32	0.00160	0.0190	0.2390
2 Delta	8 Benin	107	0.00160	0.0190	0.2390
4 Akangba	5 Ikj West	18	0.00155	0.0172	0.0650
5 Ikj West	8 Benin	280	0.00705	0.0779	1.1620
5 Ikj West	9 Ayeide	137	0.00341	0.0416	0.5210
5 Ikj West	10 Oshogbo	252	0.00341	0.0416	0.5210
6 Ajaokuta	8 Benin	195	0.00126	0.0139	0.2080
7 Aladija	24 Sapele	63	0.00160	0.0190	0.2390
8 Benin	14 Onitsha	137	0.00340	0.0416	0.5210
8 Benin	24 Sapele	50	0.00126	0.0139	0.2080
9 Ayeide	10 Oshogbo	115	0.00291	0.0349	0.4370
10 Oshogbo	17 Jebba	157	0.00398	0.0477	0.5970
11 Afam	12 Alaoji	25	0.00090	0.0070	0.1040
12 Alaoji	14 Onitsha	138	0.00350	0.0419	0.5240
13 New Haven	14 Onitsha	96	0.00240	0.0292	0.3650
15 B/Kebbi	21 Kainji	310	0.00786	0.0942	1.1780
16 Gombe	19 Jos	265	0.00670	0.0810	1.0100
17 Jebba	18 Jebba GS	8	0.00020	0.0022	0.0330
17 Jebba	21 Kainji	81	0.00205	0.0246	0.3080
17 Jebba	23 Shiroro	244	0.00620	0.0702	0.9270
19 Jos	20 Kaduna	197	0.00490	0.0599	0.9270
20 Kaduna	22 Kano	230	0.00580	0.0699	0.8740
20 Kaduna	23 Shiroro	96	0.00249	0.0292	0.3640

Table II: Bus data of the Nigerian 24-bus system

	Bus Code	Bus Name	Voltage Magntud e(PU)	Angle Degree	Load MW	Load MVAR	Generation MW	Generation MVAR
1	3	Egbin PS	1.060	0	174.00	107.00	130.00	28.00
2	3	Delta PS	1.060	0	0.00	0.00	235.00	63.00
3	2	Aja	1.060	0	200.00	124.00	0.00	0.00
4	2	Akangba	1.060	0	389.00	241.00	0.00	0.00
5	2	Ikeja west	1.060	0	484.00	300.00	0.00	0.00
6	2	Ajaokuta	1.060	0	72.00	45.00	0.00	0.00
7	2	Aladija	1.060	0	120.00	85.00	0.00	0.00
8	2	Benin	1.060	0	136.00	84.00	0.00	0.00

9	2	Aiyede	1.060	0	210.00	130.00	0.00	0.00
10	1	Oshogbo	1.060	0	194.00	120.00	0.00	0.00
11	3	Afam	1.060	0	120.00	75.00	316.00	118.00
12	2	Alaoji	1.060	0	248.00	153.00	0.00	0.00
13	2	New haven	1.060	0	182.00	112.00	0.00	0.00
14	2	Onitsha	1.060	0	0.00	0.00	0.00	0.00
15	2	B/ kebbi	1.060	0	89.00	55.00	0.00	0.00
16	2	Gombe	1.060	0	130.00	80.00	0.00	0.00
17	2	Jebba	1.060	0	11.00	8.20	0.00	0.00
18	3	Jebba GS	1.060	0	0.00	0.00	339.00	68.00
19	2	Jos	1.060	0	114.00	90.00	0.00	0.00
20	2	Kaduna	1.060	0	260.00	161.00	0.00	0.00
21	3	Kainji	1.060	0	7.00	5.20	300.00	50.00
22	2	Kano	1.060	0	126.00	140.00	0.00	0.00
23	3	Shiroro	1.060	0	7.00	36.10	140.00	30.00
24	2	Sapele	1.060	0	0.00	0.00	0.00	0.00

Code 1, Code 2, and Code 3 are used for the Slack bus, the Load buses and the voltage controlled buses respectively.

RESULTS AND DISCUSSION

LOAD FLOW RESULT

The results of the power flow solution without STATCOM and SVC and with STATCOM and SVC of the Nigerian 24-bus system are presented in the tables below. Newton Raphson;s load flow is ran first without STATCOM and SVC after which it is run with the incorporation of STATCOM and SVC into the network at the various buses that experience low voltages..

Table III: Newton Raphson’s Load Flow Result without Fact devices

Bus No	Bus Name	V KV	%V	V Pu	Angle Degree	Load MW	Load MVAR	Generation MW	Generation MVAR
1	Egbin PS	310.93	94.22	1.017	-3.2	174.00	107.00	130.00	28.00
2	Delta PS	302.448	91.65	0.9715	-2.9	0.00	0.00	235.00	63.00
3	Aja	310.875	94.20	0.9986	-3.3	200.00	124.00	0.00	0.00
4	Akangba	311.222	94.31	0.9997	-3.2	389.00	241.00	0.00	0.00
5	Ikeja west	311.36	94.35	1.0001	-3.2	484.00	300.00	0.00	0.00
6	Ajaokuta	302.507	91.67	0.9717	-3.1	72.00	45.00	0.00	0.00
7	Aladija	302.39	91.63	0.9713	-3.0	120.00	85.00	0.00	0.00
8	Benin	302.722	91.73	0.9724	-3.0	136.00	84.00	0.00	0.00
9	Aiyede	321.133	97.31	1.0315	-1.5	210.00	130.00	0.00	0.00
10	Oshogbo	330	100.00	1.0600	0.0	194.00	120.00	1878.606	2481.676
11	Afam	288.021	87.28	0.9252	-3.9	120.00	75.00	316.00	118.00
12	Alaoji	288.061	87.29	0.9253	-3.9	248.00	153.00	0.00	0.00
13	New haven	293.065	88.8	0.9414	-4.1	182.00	112.00	0.00	0.00
14	Onitsha	294.269	89.17	0.9452	-3.8	0.00	0.00	0.00	0.00
15	B/ kebbi	320.193	97.03	1.0285	-1.2	89.00	55.00	0.00	0.00
16	Gombe	296.075	89.72	0.9510	-6.1	130.00	80.00	0.00	0.00
17	Jebba	324.604	98.36	1.0427	0.1	11.00	8.20	0.00	0.00
18	Jebba GS	324.602	98.36	1.0427	0.1	0.00	0.00	339.00	68.00
19	Jos	301.946	91.50	0.9699	-4.4	114.00	90.00	0.00	0.00
20	Kaduna	308.464	93.47	0.9908	-2.7	260.00	161.00	0.00	0.00
21	Kainji	324.288	98.27	1.0417	0.2	7.00	5.20	300.00	50.00
22	Kano	300.845	91.17	0.9664	-3.8	126.00	140.00	0.00	0.00
23	Shiroro	310.676	94.14	0.9979	-2.2	7.00	36.10	140.00	30.00
24	Sapele	302.649	91.71	0.9721	-3.0	0.00	0.00	0.00	0.00

From the result, it was observed that the voltage magnitude of bus 11, 12, 13, 14, 16 and 22 are weak with the voltage at bus 11 being 0.9252pu, with bus 12 having 0.9253pu, bus 13 having 0.9414pu bus 14 having 0.9452pu, bus 16 having 0.9510pu while bus 22

has 0.9664pu, the weakest bus being bus 11.i.e. Afam(0.9252 pu), Alaoji (0.9253 pu), New Heaven (0.9414 pu), Onitsha (0.9452 pu), Gombe (0.9510 pu), Kano (0.9664).

Table IV: Line losses without fact devices

FROM BUS	TO BUS	LINE NO	LOSSES (MW)	LOSSES (MVar)
OSHOGBO	BENIN	L ₁₀₋₈	9.1017	52.4589
AJAOKUTA	BENIN	L ₆₋₈	0.2539	-3.6625
KADUNA	JOS	L ₂₀₋₁₉	1.9652	-6.4743
SAPELE	BENIN	L ₂₄₋₈	0.065	-0.9416
SAPELE	ALADIJA	L ₂₄₋₇	0.1167	-1.2988
ALAOJI	AFAM	L ₁₂₋₁₁	0.0188	-0.1835
JOS	GOMBE	L ₂₀₋₁₆	2.3676	-18.5929
BENIN	IKEJA WEST	L ₈₋₅	2.3741	-27.2672

JEBBA	JEBBA GS	L 17-18	0.0023	-0.0225
JEBBA	KAINJI	L 17-21	0.2316	-2.3723
AKAMGBA	IKEJA WEST	L 4-5	0.0452	0.0539
BENIN	DELTA	L 8-2	0.2017	-2.1659
DELTA	ALADIJA	L 2-7	0.0698	-0.5331
EGBIN	IKEJA WEST	L 1-5	0.1315	-1.2338
JEBBA	SHIRORO	L 17-23	3.5401	-2.4043
JEBBA	OSHOGBO	L 17-10	1.1302	-6.1444
AJA	EGBIN	L 3-1	0.0265	-0.3133
ONITSHA	NEW HEAVEN	L 14-13	0.3643	-1.5413
BENIN	ONITSHA	L 8-14	1.7462	8.7712
SHIRORO	KADUNA	L 23-20	0.6402	0.9957
OSHOGBO	AIYEDE	L 10-9	3.5960	32.6789
IKEJA WEST	AIYEDE	L 5-9	3.1037	23.8379
IKEJA WEST	OSHOGBO	L 5-10	6.2188	49.1495
KAINJI	KEBBI	L 21-15	3.2690	-35.2167
ONITSHA	ALAOJI	L 14-12	1.0502	0.5510
KADUNA	KANO	L 20-22	1.9868	-12.7635
		TOTAL	65.606057	687.176238

Table V: Load Flow Result with STATCOM inserted into the network

Bus No	Bus Name	V KV	%V	V Pu	Angle Degree	Shunt Mvar Injected	Load MW	Load MVAR	Generation MW	Generation MVAR
1	Egbin PS	316.792	96.00	1.0176	-3.3	0.00	174.00	107.00	130.00	28.00
2	Delta PS	302.386	97.09	1.0291	-3.2	0.00	0.00	0.00	235.00	63.00
3	Aja	316.738	95.98	1.0174	-3.3	0.00	200.00	124.00	0.00	0.00
4	Akangba	317.077	96.08	1.0185	-3.2	0.00	389.00	241.00	0.00	0.00
5	Ikeja west	317.212	96.12	1.0189	-3.2	0.00	484.00	300.00	0.00	0.00
6	Ajaokuta	320.406	97.09	1.0292	-3.3	0.00	72.00	45.00	0.00	0.00
7	Aladija	320.321	97.07	1.0289	-3.2	0.00	120.00	85.00	0.00	0.00
8	Benin	320.606	97.15	1.0298	-3.2	0.00	136.00	84.00	0.00	0.00
9	Aiyede	323.557	98.05	1.0174	-3.3	0.00	210.00	130.00	0.00	0.00
10	Oshogbo	330	100.00	1.0600	0.0	0.00	194.00	120.00	1866.823	1425.06
11	Afam	323.4	98.00	1.0388	-4.2	-81.596	120.00	75.00	316.00	118.00
12	Alaoji	323.4	98.00	1.0388	-4.2	-178.496	248.00	153.00	0.00	0.00
13	New haven	323.4	98.00	1.0388	-4.3	-125.589	182.00	112.00	0.00	0.00
14	Onitsha	323.4	98.00	1.0388	-4.0	-151.347	0.00	0.00	0.00	0.00
15	B/ kebbi	322.995	97.88	1.0375	-1.2	0.00	89.00	55.00	0.00	0.00
16	Gombe	323.4	98.00	1.0388	-6.0	-124.386	130.00	80.00	0.00	0.00
17	Jebba	327.325	99.19	1.0514	0.1	0.00	11.00	8.20	0.00	0.00
18	Jebba GS	327.323	99.19	1.0514	0.1	0.00	0.00	0.00	339.00	68.00
19	Jos	320.372	97.08	1.0291	-4.4	0.00	114.00	90.00	0.00	0.00
20	Kaduna	321.714	97.49	1.0334	-2.7	0.00	260.00	161.00	0.00	0.00
21	Kainji	327.024	99.10	1.0504	0.2	0.00	7.00	5.20	300.00	50.00
22	Kano	323.4	98.00	1.0388	-3.9	-175.254	126.00	140.00	0.00	0.00
23	Shiroro	322.46	97.72	1.0358	-3.2	0.00	7.00	36.10	140.00	30.00
24	Sapele	320.544	97.13	1.0296	-3.2	0.00	0.00	0.00	0.00	0.00

Table VI : Line losses with STATCOM inserted

FROM BUS	TO BUS	LINE NO	Losses (MW)	Losses (MVar)
OSHOGBO	BENIN	L 10-8	5.0031	20.8645
AJAOKUTA	BENIN	L 6-8	0.2838	-4.1205
KADUNA	JOS	L 20-19	1.7965	-11.7804
SAPELE	BENIN	L 24-8	0.0725	-1.0600
SAPELE	ALADIJA	L 24-7	0.1286	-1.4840
ALAOJI	AFAM	L 12-11	0.0205	-0.2560
JOS	GOMBE	L 20-16	2.5815	-23.5041
BENIN	IKEJA WEST	L 8-5	2.2755	-32.5008
JEBBA	JEBBA GS	L 17-18	0.0024	-0.0231
JEBBA	KAINJI	L 17-21	0.2344	-2.4253
AKAMGBA	IKEJA WEST	L 4-5	0.0458	0.0434
BENIN	DELTA	L 8-2	0.222	-2.4807
DELTA	ALADIJA	L 2-7	0.0752	-0.6353

EGBIN	IKEJA WEST	L 1-5	0.1343	-1.305
JEBBA	SHIRORO	L 17-23	2.8089	-12.6266
JEBBA	OSHOGBO	L 17-10	0.892	-9.1621
AJA	EGBIN	L 3-1	0.0273	-0.3278
ONITSHA	NEW HEAVEN	L 14-13	0.3678	-0.7697
BENIN	ONITSHA	L 8-14	0.9891	-2.5519
SHIRORO	KADUNA	L 23-20	0.5334	-0.7938
OSHOGBO	AIYEDE	L 10-9	2.8823	24.0423
IKEJA WEST	AIYEDE	L 5-9	2.3627	14.3999
IKEJA WEST	OSHOGBO	L 5-10	4.884	32.3874
KAINJI	KEBBI	L 21-15	3.3172	-35.9233
ONITSHA	ALAOJI	L 14-12	0.621	-7.3946
KADUNA	KANO	L 20-22	1.9104	-18.1194
		TOTAL	53.822922	467.228506

After observing the various buses with weak voltages, STATCOM was then inserted at the weak buses. i.e. buses 11, 12, 13, 14, 16 and 22 and simulated using Newton Raphson’s algorithm.

Comparing the Load flow result of Table III. and that of Table VII, it was observed that there was an improvement of the bus voltages at the weak buses. i.e. at buses 11, 12, 13, 14, 16 and 22 with bus 11 having 1.0388pu, bus 12 having 1.0388pu, bus 13 having 1.0388pu, bus 14 having 1.0388pu, bus 16 having 1.0388pu and bus 22 with a bus voltage of 1.0388pu.

Apart from these buses, there was also an improvement in the voltages at the remaining 18 buses not directly connected to the STATCOM because of the presence of STATCOM at these buses.

Similarly a comparison of the line losses in Table IV and Table VI shows that there was a reduction in both the power loss as well as in the reactive power loss when STATCOM was inserted with the power loss being reduced from 65.606057MW to 53.822922 MW while the reactive power loss was reduced from 687.176238 MVar to 467.228506 MVar

Table VII : Load flow result with SVC inserted into the network

Bus No	Bus Name	V KV	%V	V Pu	Angle Degree	Shunt Mvar Injected	Load MW	Load MVAR	Generation MW	Generation MVAR
1	Egbin PS	316.13	95.8	1.0154	-3.3	0.00	174.00	107.00	130.00	28.00
2	Delta PS	318.358	96.47	1.0226	-3.1	0.00	0.00	0.00	235.00	63.00
3	Aja	316.076	95.78	1.0153	-3.3	0.00	200.00	124.00	0.00	0.00
4	Akangba	316.416	95.88	1.0164	-3.2	0.00	389.00	241.00	0.00	0.00
5	Ikeja west	316.551	95.92	1.0168	-3.2	0.00	484.00	300.00	0.00	0.00
6	Ajaokuta	318.382	96.48	1.0227	-3.3	0.00	72.00	45.00	0.00	0.00
7	Aladija	318.294	96.45	1.0224	-3.2	0.00	120.00	85.00	0.00	0.00
8	Benin	318.584	96.54	1.0233	-3.2	0.00	136.00	84.00	0.00	0.00
9	Aiyede	323.284	97.96	1.0384	-1.5	0.00	210.00	130.00	0.00	0.00
10	Oshogbo	330	100.00	1.0600	0.0	0.00	194.00	120.00	1867.259	1552.982
11	Afam	320.1	97.00	1.0282	-4.2	-85.002	120.00	75.00	316.00	118.00
12	Alaoji	320.1	97.00	1.0282	-4.2	-178.577	248.00	153.00	0.00	0.00
13	New haven	320.1	97.00	1.0282	-4.3	-125.635	182.00	112.00	0.00	0.00
14	Onitsha	320.1	97.00	1.0282	-4.0	-78.118	0.00	0.00	0.00	0.00
15	B/ kebbi	322.613	97.76	1.0363	-1.2	0.00	89.00	55.00	0.00	0.00
16	Gombe	320.1	97.00	1.0282	-6.0	-110.21	130.00	80.00	0.00	0.00
17	Jebba	326.954	99.08	1.0502	0.1	0.00	11.00	8.20	0.00	0.00
18	Jebba GS	326.951	99.08	1.0502	0.1	0.00	0.00	0.00	339.00	68.00
19	Jos	318.01	96.37	1.0215	-4.4	0.00	114.00	90.00	0.00	0.00
20	Kaduna	319.903	96.94	1.0276	-2.7	0.00	260.00	161.00	0.00	0.00
21	Kainji	326.651	98.99	1.0492	0.2	0.00	7.00	5.20	300.00	50.00
22	Kano	320.1	97.00	1.0282	-3.9	-145.436	126.00	140.00	0.00	0.00
23	Shiroro	320.85	97.23	1.0306	-2.2	0.00	7.00	36.10	140.00	30.00
24	Sapele	318.52	96.52	1.0231	-3.2	0.00	0.00	0.00	0.00	0.00

Table VIII : Line losses with SVC inserted

FROM BUS	TO BUS	LINE NO	Losses (MW)	Losses (MVar)
OSHOGBO	BENIN	L 10-8	5.2349	22.7031
AJAOKUTA	BENIN	L 6-8	0.2803	-4.0674
KADUNA	JOS	L 20-19	1.7945	-11.3674
SAPELE	BENIN	L 24-8	0.0716	-1.0463
SAPELE	ALADIJA	L 24-7	0.1272	-1.4629
ALAOJI	AFAM	L 12-11	0.0202	-0.2502
JOS	GOMBE	L 20-16	2.5239	-23.2417
BENIN	IKEJA WEST	L 8-5	2.226	-32.5622
JEBBA	JEBBA GS	L 17-18	0.0024	-0.023
JEBBA	KAINJI	L 17-21	0.0234	-2.4181
AKAMGBA	IKEJA WEST	L 4-5	0.0457	0.0446
BENIN	DELTA	L 8-2	0.2196	-2.4447
DELTA	ALADIJA	L 2-7	0.0746	-0.6237
EGBIN	IKEJA WEST	L 1-5	0.134	-1.297
JEBBA	SHIRORO	L 17-23	2.8582	-11.7992
JEBBA	OSHOGBO	L 17-10	0.9148	-8.8663
AJA	EGBIN	L 3-1	0.0272	-0.3262
ONITSHA	NEW HEAVEN	L 14-13	0.3633	-2.6767
BENIN	ONITSHA	L 8-14	0.8921	-3.4967
SHIRORO	KADUNA	L 23-20	0.5402	-0.6403
OSHOGBO	AIYEDE	L 10-9	2.9498	24.861
IKEJA WEST	AIYEDE	L 5-9	2.4287	15.2499
IKEJA WEST	OSHOGBO	L 5-10	5.0064	33.9354
KAINJI	KEBBI	L 21-15	3.3106	-35.8266
ONITSHA	ALAOJI	L 14-12	0.609	-7.2372
KADUNA	KANO	L 20-22	1.8646	-18.0217
		TOTAL	54.259409	481.460877

Table IX: Bus Voltage and Reactive Power comparison of STATCOM and SVC

Bus no	Bus Voltage Without Facts (Pu)	Bus Voltage with STATCOM(Pu)	Bus Voltage With SVC (Pu)	Reactive Power Supplied by STATCOM(Pu)	Reactive Power Supplied by SVC (Pu)
(11) Afam	0.9252	1.0388	1.0282	-0.0573	-0.0547
(12) Alaoji	0.9253	1.0388	1.0282	-0.1253	-0.1150
(13)New Haven	0.9414	1.0388	1.0282	-0.0881	-0.0809
(14) Onitsha	0.9452	1.0388	1.0282	-0.1062	-0.0503
(16) Gombe	0.9510	1.0388	1.0282	-0.0873	-0.0710
(22) Kano	0.9664	1.0388	1.0282	-0.1230	-0.0936

Comparing the Load flow result of Table 3.0 and that of Table 7.0, it was observed that there was an improvement of the bus voltages at the weak buses when SVC was inserted into the network i.e. at buses 11, 12, 13, 14, 16 and 22 with bus 11 having 1.0282pu, bus 12 having 1.0282pu, bus 13 having 1.0282pu, bus 14 having 1.0282pu, bus 16 having 1.0282pu and bus 22 with a bus voltage of 1.0282pu.

Similarly, there was also an improvement at the remaining 18 buses not directly connected to the SVC because of the presence of SVC. However it was observed from the load flow result of Table V that the voltage improvement in STATCOM was higher than that in SVC, with STATCOM offering the highest voltage improvement (1.0388pu) than SVC (1.0282pu).

Similarly comparing Table IV and Table VIII it will be observed that there was a reduction in both the power loss as well as in the reactive power loss when SVC was inserted with the power loss being reduced from 65.606057MW to 54.259409 MW while the reactive power loss was reduced from 687.176238 MVar to 481.460877MVar.. Hence there was a reduction in the active and reactive power loss in the network when SVC was inserted as compared to when there was no fact device in the network. Thus the presence of SVC in the network improved the voltages of the buses and also reduced the losses in the network. However the percentage reduction in the active and reactive power loss in the network was higher when

STATCOM was inserted than when SVC was inserted into the network. Thus STATCOM offered a higher percentage in loss reduction both in the active and reactive percentage power loss than SVC. It is seen therefore that there was more percentage reduction in the active and reactive power loss in the network when STATCOM was inserted than when SVC was inserted. Hence the presence of STATCOM in the network reduces the active and reactive power loss in the network more than when SVC was inserted

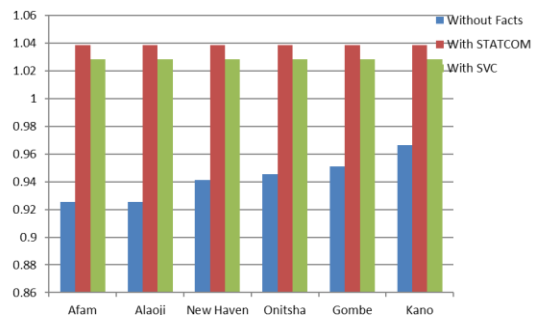

Figure 7.0: Voltage Profile Comparison of STATCOM and SVC

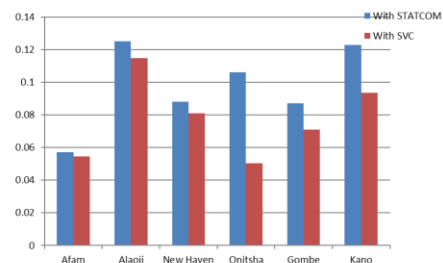

Fig 8.0 Reactive Power supplied by SVC and STATCOM

CONCLUSION

The STATCOM is a shunt device used in improving the bus voltage profile. It is commonly used to maintain a constant voltage across ac transmission lines and also serves as automatic reactive power control.

The voltage stability analysis was performed on the Nigerian 24-bus test system without fact devices and with STATCOM and SVC inserted.

After the analysis, it was discovered that there were low voltages at bus 11, 12, 13, 14, 16 and 22 which are Afam, Alaoji, New Heaven, Onitsha, Gombe and Kano respectively.

It was observed that there was an improvement in the bus voltages when the fact devices were inserted at the weak buses with STATCOM offering more voltage improvement than SVC. Consequently there was also voltage improvement in other buses not directly connected to the fact devices.

Table III shows the result of the load flow analysis without the fact devices..

From the load flow result, both STATCOM and SVC were able to improve the bus voltages of the weak buses in the network as well as other buses not directly connected to them with STATCOM offering the highest voltage improvement of 1.0388pu. SVC also offered a reasonable voltage improvement of 1.0282pu .Hence STATCOM offered a more robust improvement than SVC.

The total reactive and active power loss in the network without the Fact devices inserted were 687.1762MVar and 65.6061MW respectively.

STATCOM also generated a higher reactive power than SVC in the weak buses with STATCOM having a reactive power loss of 467.2285MVar giving a total reduction of 32.01% in the reactive power loss of the network while SVC had a total reactive power loss of 481.4609MVar giving a total reduction of 29.94% in the reactive power loss in the network.

Similarly, STATCOM had an active power loss of 53.8229MW giving a total reduction of 17.96% in the active power loss of the network while SVC had an active power loss of 54.2594MW giving a total reduction of 17.30% in the active power loss of the network.Both STATCOM and SVC improve the static voltage of the bus but STATCOM provided a higher reactive power support than SVC. Hence we conclude that STATCOM is most suitable for static as well as dynamic voltage restoration and offers a robust option than SVC.

Thus the presence of STATCOM and SVC in the network performs the following.

- i. Improves the voltage supply.
- ii. Provides reactive power support with a faster response time.
- iii. Prevents voltage collapse as well as voltage sag.
- iv. Reduces losses (Both real and reactive losses) associated with the system.

REFERENCES

- [1] Anbarasan, A. and Sanavullah, M. Y (2012). Voltage stability improvement in power system by using statcom. *International Journal of Engineering Science and Technology (IJEST)*.1-8.
- [2] Adebayo I. G, Aborisade, D. O. and Oyesina, K. A. (2013). Steady state voltage stability enhancement using Static Synchronous Series Compensator(SSSC); A case study of Nigerian 330kv grid system. *Research Journal in Engineering and Applied Sciences*, 2(1): 54-61.
- [3] Anwar, S. and Tanmoy, D. (2014).Voltage stability improvement using STATCOM and SVC.*International Journal of Computer Applications*, 88.
- [4] Adepoju, G. A. and Komolafe, O. A. (2011). Analysis and Modelling of Static Synchronous Compensator (STATCOM): a comparison of power injection and current injection models in power flow study. *International Journal of Advanced Science and Technology*. 36: 65-75.
- [5] Champa N, Sumita D, Minakshi D. B. and Chakraborty A. K. Study and simulation of the SVC and STATCOM effect on voltage collapse

- and critical fault clearing time. *International Journal of Modeling and Optimization*. 2: 1-4.
- [6] Das, S. K and Moharana J. K. (2012). Design and simulation of small signal model of a STATCOM for reactive power compensation on variation of DC link voltage. *International Journal of Engineering and Innovative Technology*. 2: 1-7
- [7] Ganesh P. P, Chatterji S. and Mathew, L. (2012). Performance analysis of 48-Pulse VSC-based STATCOM in mitigation of voltage dip caused by the starting of a high power Induction-Motor. *International Journal of Engineering Research and Development*. 4: 01-05.
- [8] Hiroshi Y, Toshiaki S, Michiharu T, Katsuhiko M, Isao I, John J. P. and Gregory F. R. (2000). Study of a STATCOM application for voltage stability evaluated by dynamic PV curves and Time Simulations. *International Journal of Engineering and Innovative Technology*. 8: 1-7.
- [9] Haniyeh, M. AND Mohammad, S. (2013). Power flow study and Performance of STATCOM and TCSC in improvement voltage stability and loadability Amplification in Power System. *International Journal of Applied Power Engineering (IJAPE)*. 2: 15-26.
- [10] Hussain, K. and Praveen, J. (2012). Voltage sag Mitigation using distribution Static Compensator System. *International Journal of Engineering and Technology*. 2: 756-760.
- [11] Radha K, Rafi V, Subrahmanyam, J. and Mazhar, S. (2012). A novel on coordinated voltage control scheme for SEIG-Based wind park utilizing substation statcom and ULTC transformer. *Global journal of Research of Engineering*. 12 (5) 23-28.
- [12] SajediHir M, Hoseinpoor Y, MosadeghArdabili, P. and Pirzadeh, T. (2011). Analysis and simulation of a STATCOM for Midpoint voltage regulation of transmission lines. *Australian Journal of Basic and Applied Sciences*. 5 (10): 1157-1163
- [13] Snehasish P, Suvarun D, Snehasish, B. and Sankha, S. G. (2012). Digital simulation of a STATCOM based on twelve pulse VSC for voltage control application in power system. *Indian Journal of Science Research*. 3 (2): 135-144.
- [14] Tanaya D, Palukuru N, Sunita H. D. and Subrata P. (2013). Voltage stability assessment of a power system incorporating FACTS in equivalent mode. *Journal of Electrical Systems*. 9 (4): 440-452.
- [15] Tanaya D. P, Nagendra, S. H. and Subrata, P. (2013). Voltage stability assessment of a power system incorporating FACTS in equivalent mode. *Journal of Electrical Systems*. 9 (4): 1-13.