

# Transient Stability Assessment of Nigerian 330kv Power Grid Using Modified Euler Technique

NLERUM, S. K.<sup>1</sup>, BRAIDE, S.L<sup>2</sup>, AMADI, H.N<sup>3</sup>

<sup>1, 2, 3</sup> *Department of Electrical Engineering, Rivers State University, Port Harcourt, Nigeria.*

**Abstract-** *The study examined transient stability assessment of Nigeria 330kv power grid within Benin regional control centre. The dissertation investigated the impact of the three-phase fault created along Delta – Benin transmission line. The critical clearing angle and time of circuit breaker were also determined using Artificial Neural Network (ANN) techniques. The network was modeled in Electrical transient analyzer program (ETAP 12.6) software and the swing equation was solved using modified Euler Method. The data obtained from simulation were used to train the artificial neural network in MATLAB using back propagation algorithm. Results show that the generating stations that were mostly affected during the fault were sapele generating station, Delta generating station and Ihovbor generating station with their corresponding bus voltages of 182.2kv, 170.5kv and 173.1kv respectively. Similarly, the load centres that were also affected by the fault were Aladja and Asaba transmission stations with their corresponding bus voltages of 171.9kv and 195.1kv respectively. The critical clearing angle is 77.220 degree both for modified Euler and artificial neural network and the critical clearing time of the circuit breaker is 0.200seconds for modified Euler method and 0.220seconds for artificial neural network. Based on this findings, it is concluded that transient stability study is important for proper planning and improvement of Nigeria national grid by Transmission Company Nigeria (TCN).*

**Indexed Terms-** *Eular Technique, power grid, transient stability.*

## I. INTRODUCTION

In recent time, power system has advance in terms of size and complexity. Hence, the need for the deployment of intelligent systems becomes inevitable for planning, operation, control and optimization. By

this way, solution of network problem becomes easier. Traditional methods are usually not able to solve power system problems in real time. In general, such methods are time-consuming and computationally expensive, and are not suitable for online monitoring and control. Reliable electricity been the basis for the socio-economic and technological development of any society (Gupta, 2016). electric power system infrastructure has increased in size and complexity. The Nigerian 330kV grid interconnects all major generating stations and load centres in the country. It consists of numerous generating stations, transmission lines, and power transformers scattered within the country (Odia, 2017).

The extensive interconnection of the grid network makes it more complex and due to economic and environmental constraints the stability of the system is altered thereby pushing it to operate closer to their limits and disposing the grid to different forms of system disturbance. This indeed has brought about the management of the power system infrastructures to operate at a level resulting in poor evacuation of power predicated on the weakness of the existing transmission infrastructures. Thereby, making coordination and control of the power system more difficult to achieve (Egeruoh, 2018).

The major challenge confronting the efficiency of the 330kV grid is system instability or disturbance due to fault. Instability in power system has undesirable consequences ranging from limitation in the quantity of power evacuated, loss of synchronization by generating stations and voltage collapse experienced by consumers (Enemuoh, 2016). The ever rising cost of modifying the grid network has made it imperative for the Transmission Company of Nigeria (TCN) to use different design alternatives, and effect a wholesome study of the impact on the system predicated on specific predictions under steady and transient state condition. In order to make this an

achievable possibility, artificial intelligent tools are embedded in digital to assist the system engineers and planners use large network data to solve complex power system problem. Artificial intelligence if completely integrated into power system can effectively solve complex network problems and also perform a real time monitoring and control of power system infrastructure (Hague, 2012).

According to Rastgoufard (2018) the foremost benefits of deploying artificial intelligence tools in power system are their speed, robustness, and relative insensitivity to missing data. The study proposed the adaptation of artificial neural network to determine the critical clearing time and angle of circuit breaker needed for the elimination of three phase fault in a transmission line.

## II. STATEMENT OF THE PROBLEM

Transient stability analysis in recent times has become a major challenge in power system operation. The Nigerian 330kV power system network lack flexibility of restoring system capability when highly stressed which results into high rate of instability. The joint generation and operation 2020 annual meeting the total forced outage recorded by the transmission company of Nigeria (TCN) in 2020 is 53.4%, 42.43% in 2019 and 35.1 % in 2018. In order to improve the system, an evaluation of the 330kV grid network is required to ascertain its existing capacity to withstand disturbance while maintaining quality of service.

## III. AIM AND OBJECTIVES OF THE STUDY

The aim of the study is to evaluate transient stability assessment of Nigerian 330 KV power grid using modified Euler technique. In order to achieve our aim, we rely on the following objectives.

- i. To model and simulate the existing Benin Sub-regional 330kV grid network in Etap 12.6 software environment.
- ii. To determine the most affected generating stations in the network after the occurrence of a three phase (3- $\theta$ ) fault along Delta-Benin Transmission line
- iii. To determine the critical clearing angle and time of the circuit breaker using artificial neural network techniques.

- iv. To determine whether or not the system-maintained synchronism when the fault was cleared.
- v. To compare the ANN result with Modified Euler Method.

## IV. LITERATURE

### • Power System Stability

Hussain (2017) defined electrical power system stability as the quality of the system that enhances it to stay in a state of equilibrium under normal conditions and to obtain an acceptable state of equilibrium after undergoing a disturbance. According to Barshar (2016) Instability can occur in a system network under different situations based on the configuration of the system and its operating mode. In the field of power system operation, stability problem has been loss of synchronism in common synchronous electrical machines.

The indispensable condition under which a perfect network can be operated on is that all synchronous electrical machines must operate in optimal synchronization under steady state condition. This aspect is enhanced by the basic dynamics of the angles of the generator rotor and power-angle relationship. In stability studies, the main concern is the response of the system when it is faced with appropriate transient disturbance. It may be a very minute or almost negligible disturbance which could be due to load changing conditions or of large value ranging from short-circuit on transmission networks or very obvious and conspicuous disturbances such as loss of large load or generator or may be occurring as breakage of tie-line between two possible sub-systems.

### • Classification of Electrical Power System Stability

The electrical power system stability is classified into three. They include: Rotor Angle Stability, frequency stability and voltage stability. The rotor angle stability is further categorized into two namely, small disturbance angle stability and transient stability. The voltage stability is further divided into two namely, large disturbance voltage stability and small disturbance voltage stability. The frequency stability is divided into short-term and long term frequency stability (Prabha et al., 2014; Barsha & Chin, 2016;

Gupta, 2016; Ashfaq, 2017; Schlabbach & Rafalski, 2018).

- Power Flow Analysis Methods

According to Stevenson (2019), the concept of power flow study as it involves a system network is an intensive study of the mode of operation of the network and how it produces results associated with the normal conditions. In his view, Ibe (2012) asserted that solving of power flow problems involves the process of ascertaining the respective appropriate bus voltages and line current flow within a specified network based on a defined loading schedule. He added that digital solution of the power flow problem requires iterative process by assigning an estimated value to an arbitrary bus voltage and calculating the new value for each bus voltage repeatedly until the change at respective buses diminishes to a minimum value. The methods for power flow analysis are Gauss-Seidel Method, Newton-Raphson Method and Fast-Decoupled Method (Acha, 2014; Gupta, 2016).

- Bus Classification

According to Saadat (2016) a bus is an inter-connection point where different lines, loads and generating plants are duly connected within a network. In power system, each bus is associated with four quantities which involve the size of voltage and phase angle. Other parameters of relevance are the respective values of the active and reactive power. The first two out of these components and the last two are computed through the result of equation depending upon which quantity that was specified (Wood, 2019). The bus classification include: load bus, voltage control bus, stack bus.

- Methods of Transient Stability Assessment

To assess the stability status of a power system during a fault event, information on the system response should be adequately obtained. Different methods have been proposed by different authors to obtain TSA response such as time domain simulation (TDS) method, direct methods, and hybrid method.

Table 2.2: Literature Review Table Comparing Classical Methods for Computing TSA

Methods	Relevant Literature	Break throughs	Draw backs
Time domain simulation method (TDS)	N. Wahab et al (2018)	It has good modeling capacity.	The method requires much computational time
	M. Li et al (2016)	Fast and Reliable in determining critical clearing time	It can generate inadequate information
Direct Method	H. Bostti et al (2018)	It requires less computational time compared to time domain simulation.	Determining the accurate energy function is difficult because it uses concept of transfer energy function.
	C. Mishra et al (2018)	Information about stability margin is adequately generated	It becomes inaccurate as the network gets more complex and larger.
Hybrid Method	F.R Sevilla et al (2015)	It combines both time domain simulation and transient energy function method for computing transient stability assessment	Representation of system parameter is difficult due to the uses transient energy function concept in computation

A. Shamisa et al (2016)	Can predict power system stability and determines critical clearing angle	Only applicable to one or two machine system connected to infinite bus bar.
-------------------------	---	---

• Knowledge Gap

Different method has been used to compute transient stability assessment in power system but could not solve complex network problems and perform real time monitoring. The artificial intelligent method was able to overcome the limitations recorded by the time domain simulation methods. The artificial intelligence was considered in this study due to it foremost benefits in solving transient stability assessment problem which includes high computational speed, robustness, insensitivity to missing data, effectiveness in solving complex network problems and performance of real time monitoring and control.

• Research Materials Used

The research materials used includes the following

- i. The single line diagram of the existing Benin sub-regional Nigerian 330kV grid network
- ii. The line parameters such as resistance, impedance, reactance, cross sectional area and subceptances
- iii. Electrical Transient Analyzer Program (ETAP 12.6)

iv. Mathematics Laboratory (Matlab 18b)

• Research Method Used

The research method used includes the following

- i. Collection of load, bus and line data from the transmission company of Nigeria (TCN).
- ii. Representation of Benin sub-regional Nigerian 330kV grid network in a single line diagram using Etap
- iii. Simulation of the of Benin sub-regional Nigerian 330kV grid network in ETAP software
- iv. Obtain ANN training data using MATLAB
- v. Develop a neural network model in Matlab environment
- vi. Train the neural network using feed forward back propagation algorithm to determine the critical clearing angle and time of the circuit breaker.

• Data Collection

Table 1: Generator Data

S/n	Generator ID	Operating Mode	Turbine Type	Power (MW)	Nominal Bus kV	Speed (Rpm)	P.F
1	Afam GS	Voltage Control	Gas/Steam	900	330	1500	0.85
2	Alaoji G.S	Voltage Control	Gas	120	330	1500	0.85
3	Delta G.S	Voltage Control	Gas	480	330	1500	0.85
4	Ihovbor GS	Voltage Control	Gas	450	330	1500	0.85
5	Odukpani G.S	Voltage Control	Gas	500	330	1500	0.85
6	Okpai G.S	Voltage Control	Gas/Steam	450	330	1500	0.85
7	Sapele G.S	Voltage Control	Steam	700	330	1500	0.85

Source: Transmission company of Nigeria (TCN)

Table 2: Load Data

S/N	Load ID	Rated MVA	Shunt Mvar	Bus kV
1	Aladja TS	180		330
2	Alaoji TS	280	75	330
3	Asaba TS	100		330
4	Benin North TS	80		330

5	Benin TS	300	75,75	330
6	Ikot Ekpene TS	180		330
7	New Heaven TS	200		330
8	Onitsha TS	150	75	330
9	Ugwaji TS	200		330

Source: Transmission company of Nigeria (TCN)

Table 3: Transmission Line Data

S/N	Circuit Nomenclature	Distance (KM)	Transmission Line		Line Admittance	
			From	To	(Rpu)	(1/2Bpu)
1	A1E & A2E	55	Alaoji TS	Ikot Ekpene TS	1.637-j2.626	0.208
2	B1T & B2T	137	Benin TS	Onitsha TS	5.848-j4.184	0.208
3	E1O & E2O	70.3	Odukpani GS	Ikot Ekpene TS	2.754-j3.553	0.524
4	E1U, E2U	162	Ikot Ekpene TS	Ugwaji TS	6.494-j3.891	0.308
5	E3B	137	Benin TS	Asaba TS	5.848-j4.184	0.104
6	F1A & F2A	25	Afam GS	Alaoji TS	2.754-j3.553	0.104
7	F1E & F2E	65	Afam GS	Ikot Ekpene TS	6.494-j3.891	0.104
8	G1W	30	Delta GS	Aladja TS	6.129-j9.615	0.454
9	G3B	107	Delta GS	Benin TS	4.545-j3.247	0.437
10	H1U & H2U	6.5	New Heaven TS	Ugwaji TS	1.637-j2.626	0.437
11	K1L & K2L	17.7	Odukpani GS	Adiabor TS	1.192-j0.848	0.239
12	K1T & K2T	56	Okpai GS	Onitsha TS	1.192-j0.848	0.524
13	N1T	65.8	Benin North TS	Onitsha TS	1.923-j6.456	0.954
14	S3B & S4B & S5B	50	Sapele GS	Benin TS	6.494-j3.891	0.257
15	S4G	63	Sapele GS	Aladja TS	6.494-j3.891	0.239
16	T3E	65.8	Asaba TS	Onitsha TS	2.695-j1.919	0.239
17	T3H	96	Onitsha TS	New Haven TS	0.246-j3.092	1.013
18	T4A	138	Onitsha TS	Alaoji TS	2.695-j1.919	0.257
19	U1A & U2A	157	Ugwaji TS	Aliade TS	6.494-j3.891	0.208
20	V7B	20	Ihovbor GS	Benin TS	3.846-j2.739	0.257

Source: Transmission company of Nigeria (TCN)

The Single Line Diagram of the Existing Benin Sub-regional Nigerian 330kv Grid Network after Simulation

V. RESULTS AND DISCUSSION

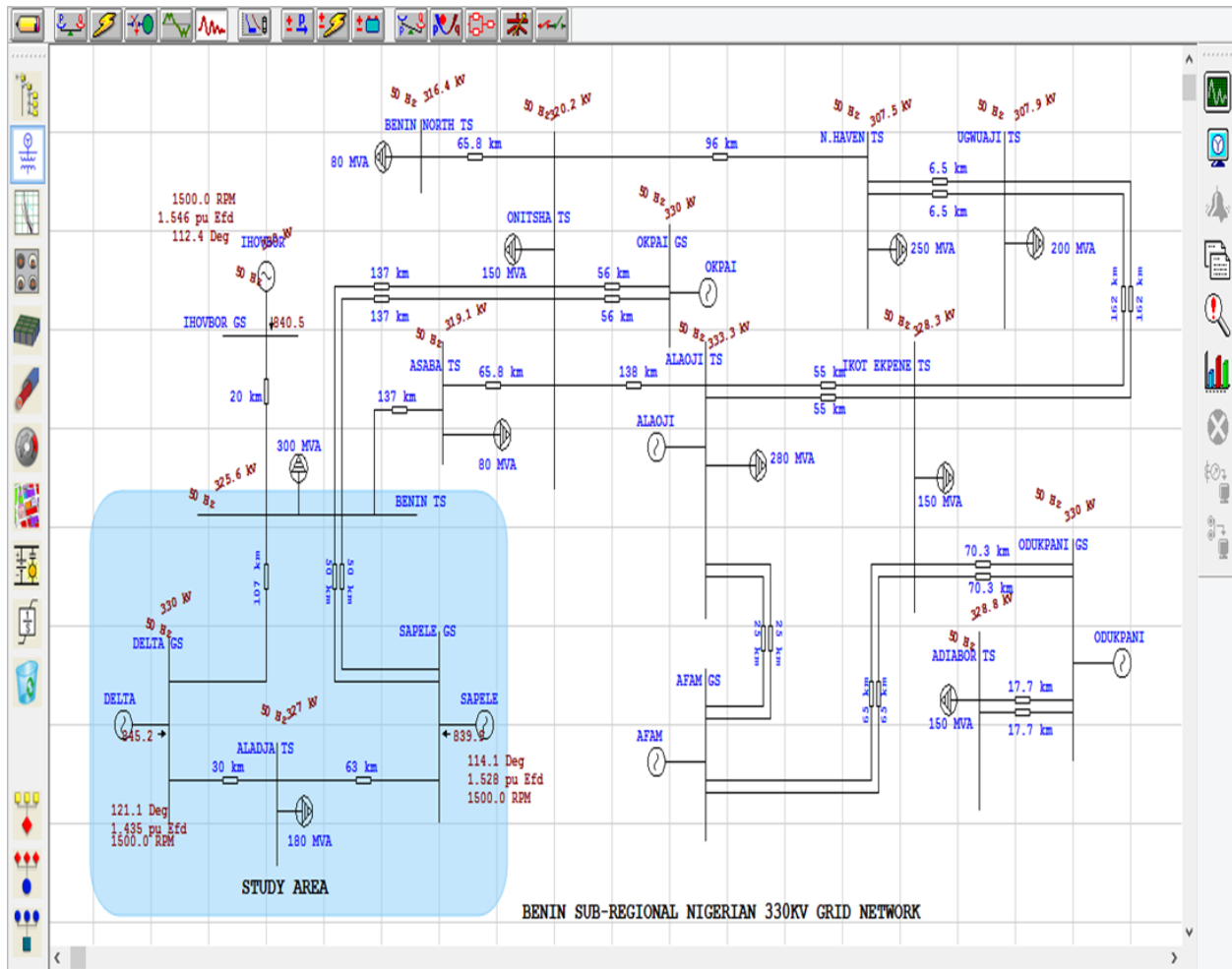

Figure 1: Model of the Existing Nigeria 330kV Network after Simulation

Figure 1 shows the performance of the Nigerian 330kV power system network. The generation, load and voltage profile of the existing network is shown in the above figure. Afam power station is used as the swing bus since it has the largest generating capacity. A simulation time step of 0.001 was used in Etap

software to increase the calculation. Also, a fault time was set at 0.2 second for a three phase-fault to occur at 80% of Benin-Delta transmission line and a clearing time was set at 0.25 seconds. The simulation lasted for 20 seconds

Table 4: Bus Voltage (kV)

SN	Bus ID	Bus Type	Nominal	Pre-Fault	During-Fault	Post-Fault
1	Afam	Gen.	330	330.1	294.3	329.3
2	Aladja TS	Load	330	327.0	171.9	317.6
3	Alaoji TS	Load	330	330.1	291.5	329.2
4	Alaoji GS	Gen.	330	330.1	291.5	329.2
5	Asaba TS	Load	330	325.0	195.2	321.0
6	Benin North TS	Load	330	321.4	217.1	318.1
7	Benin TS	Load	330	329.4	147.1	323.9
8	Delta GS	Gen.	330	330.1	170.5	320.1

9	Ihovbor GS	Gen.	330	330.1	173.1	325.0
10	Ikot Ekpene TS	Load	330	326.9	288.0	325.9
11	N.Haven TS	Load	330	318.0	245.0	313.8
12	Odukpani GS	Gen.	330	330.1	298.4	329.4
13	Okpai GS	Gen.	330	330.1	239.9	327.0
14	Onitsha TS	Load	330	325.3	219.7	322.0
15	Sapele GS	Gen.	330	330.1	182.2	322.9
16	Ugwuaji TS	Load	330	328.0	245.0	325.3

Table 4.1 shows the bus voltages at pre-fault, during fault and post-fault condition. It was observed that the bus voltages were deviating from the statutory limit of 313.45 kV-346.5 kV when fault occurred. However, the oscillation was damped after the fault was cleared. The generating stations that were mostly affected during fault are Sapele GS, Delta GS and Ihovbor GS and their corresponding bus voltages are 182.2kV,170.5kV,173.1kV respectively. Similarly, the load centres that were also affected by the fault are Aladja TS and Asaba TS with their corresponding bus voltages are 171.9kV and 195.1kV respectively.

#### 4.2 The Plot of Generator Angle

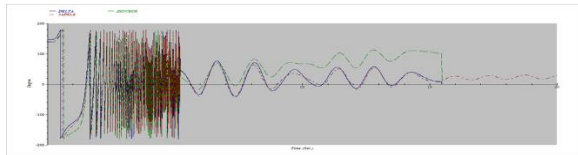

Figure 2: Plot of Generator Relative Power Angle with Time

Figure 2 shows the graph of relative power (rotor) angle with time. The graph is an indicator of the generator’s stability. Looking at the profile, at 0.00-0.19 second there were no power oscillations in the output which shows that the generators were running at synchronous speed. At 0.20-0.24 seconds it was observed that due to the fault, the generators experienced a power swing and now operates in a new power angle. At 0.25 seconds after the fault was cleared, it oscillated and was damped gradually though it will attain stability after a period as the oscillation decays away with time. Based on this behavior, we can say that the generators maintained synchronism with the grid.

- The Plot of Generator Terminal Current

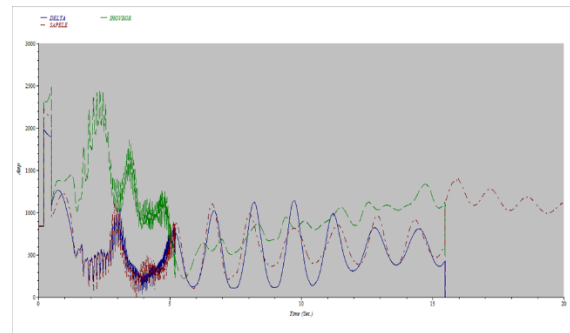

Figure 3: Plot of Generator Terminal Current with Time

Figure 3 shows the plot of generator terminal current with time. From the profile a sudden rise in generator’s terminal current was observed during fault period. After the fault was cleared the oscillations in the terminal current reduced gradually and the system reaches a stable operating condition. Based on this behavior, we can say that the generators-maintained synchronism with the grid.

Table 5 Comparison of Modified Euler and ANN

CCA (degree)		CCT (second)	
Modified Euler	ANN	Modified Euler	ANN
26.890	26.880	0.000	0.010
27.230	27.230	0.020	0.020
28.490	28.490	0.040	0.040
31.210	31.200	0.060	0.070
35.190	35.190	0.080	0.080
39.240	39.230	0.100	0.090
44.170	44.180	0.120	0.130
50.780	50.790	0.140	0.150
60.390	60.390	0.160	0.160
70.660	70.660	0.180	0.210
77.220	77.220	0.200	0.220
80.370	80.370	0.220	0.220

79.350	79.330	0.240	0.220
76.670	76.630	0.260	0.220

Table 5 shows comparison of Modified Euler and ANN method. A quick look at the table shows that the critical clearing angle is 77.220 degree for both Modified Euler and ANN. Similarly, the critical clearing time of the circuit breaker is 0.200 second for Modified Euler and 0.220 second for ANN.

### CONCLUSION

The study examined the existing Nigerian 330kV grid network within the Benin regional control centre. The network consists of seven (7) generating station, sixteen (16) buses, and nineteen (19) transmission lines. The swing equation, modified Euler’s method and ANN technique were used for the study. The network was modeled in Electrical Transient analyzer program (ETAP12.6) software to investigate the stability limit before, during and after occurrence of a three phase (3-θ) fault occurred along Delta-Benin transmission line. The most affected generating stations were identified and the fault was cleared at 0.25sec using a self-reset rely which close back the line upon clearing. The data obtained from simulation was used to train the artificial neural network in MATLAB using back propagation algorithm to determine the critical clearing angle and time of the circuit breaker. From the training result in ANN the critical clearing angle is 77.220 degree and 0.220 second. After the fault was cleared, the generator oscillated and gradually damped after a period as the oscillation decays away with time. Based on this behavior, we can say that the generators maintain synchronism. Modified Euler and ANN was compared and from the result critical clearing angle is 77.220 degree for both Modified Euler and ANN. Also, the critical clearing time of the circuit breaker is 0.200 second for Modified Euler and 0.220 second for ANN.

### CONTRIBUTION TO KNOWLEDGE

The study is valuable to the transmission company of Nigeria for proper planning of Nigerian national grid. Also serves as a guide to the power system engineers to set their relays and circuit breakers operating time to act at 0.2 seconds or less in the occurrence of a

three-phase fault to enable the system regain its power stability as quick as possible to avoid system collapse.

### RECOMMENDATIONS

Based on the findings, the following recommendations are highlighted as a measure to improve transient stability for optimum performance and reliability the power system.

1. More loops are to be created in the transmission sub-network to increase reliability and stability during disturbances.
2. The deployment of faster auto-reclosure mechanisms to facilitate the swinging synchronous generators to develop restoring torque and accentuate the stability limit of the system. Manual reclosure have been considered too sluggish to have any significant impact on the stability limit

### REFERENCES

- [1] Acha, E., Claudio, R., Hugo, A., and Cesar, A. (2004). *Facts Modelling and Simulation in Power Network*. John Wiley and Sons Ltd Southern Gate, Chichester, West Sussex, England.
- [2] Ashfaq, H. (2017) *Electrical Power Systems* (5<sup>th</sup>Edth) CBS Publishers & distributors Pvt. Ltd. 4819/XI, 24 Ansari Road, New delhi
- [3] Bashar, S.A and Chin, KG (2016) Power system frequency stability and control: Survey *International Journal of Applied Engineering Research* 11(8), 5688-5695
- [4] Egeruoh,C.C (2018). *Longterm transmission expansion planning for Nigeria deregulated power system* (Master dissertation) Deelft University of technology, Madrid.
- [5] Enemuoh, F.O (2016) *Simulation modelling of voltage stability of an interconnected electric power system network* (Ph.D Thesis) University of Nigeria, Nsuka.
- [6] Gupta, B.R. (2016). *Power system analysis and design*. Wheeler publishing Allahabard.
- [7] Haque ,M.H, and Rahim A. (2012) ‘Determination of first swing stability limit of multi machine power systems through Taylors series expansion’. *IEE proceedings* 136: 373-380



- [8] Hussan , H.A. (2017). *A practical method for power system stability and security*. (Master dissertation) University of New orleans, USA
- [9] Ibe, A.O., (2012). *Power system analysis*. Enugu: Odus Press.
- [10] Odia, A. (2017) *Transient stability assessment of the Nigerian 330kV network*. (Master dissertation) University of Port Harcourt, Nigeria.
- [11] Prabha,K., Joh, P., Venkat,A., Goran, A., Anjab,B., (2004). Definition and classification of power system stability. *IEEE Transaction on Power System* 19(2)1387-1401
- [12] Rastgoufard S. (2018). *Applications of artificial intelligence in power system*. University of New Orleans. Thesis and Dissertation
- [13] Saadat H. (2016) 'Power System Analysis, New Delhi,' Tata McGraw-Hill Publishing Company Limited. 189- 486.
- [14] Schlabbach, J and Rafalski,K (2018)*Power system engineer: Planning, design and operation of power systems and equipment*. University of Applied science. Bielefeld:
- [15] Stevenson, W.D, (2019). *Power System Analysis*. New Delhi: McGraw Hill.
- [16] Wood, A.J., Wollenberg, B.F. (2016). Power generation operation *WSEAS Transaction on Power Systems*, 17, 12-17