

Smart Dustbin Using Arduino

SAYALI SONDE¹, RUPESH MORE², DIPESH BOPCHE³, MONICA GUNJAL⁴, GAYATRI LONDHE⁵

^{1, 2, 3} Student, Dr. D.Y. Patil Institute of Technology

^{4, 5} Assistant Professor, Dr. D.Y. Patil Institute of Technology, Pimpri, Pune

Abstract- The main objective of the project is to design a smart dustbin which will help in keeping our environment clean and also eco-friendly. We are inspired from Swaach Bharat Mission. Nowadays technologies are getting smarter day-by-day so, as to clean the environment we are designing a smart dustbin by using Arduino. This smart dustbin management system is built on the microcontroller-based system having ultrasonic sensors on the dustbin. If dustbin is not maintained than these can cause an unhealthy environment and can cause pollute that affect our health. In this proposed technology we have designed a smart dustbin using Arduino UNO, along with ultrasonic sensor, servo motor, and battery jumper wire. After all hardware and software connection, now Smart Dustbin program will be run. Dustbin lid will when someone comes near at some range than wait for user to put garbage and close it. It's properly running or not. For social it will help toward health and hygiene, for business for we try to make it affordable to many as many possible. So that normal people to rich people can take benefit from it.

Indexed Terms- Arduino UNO, Ultrasonic sensor, Servo motor, Jumper wires, Buzzer, Power Supply.

I. INTRODUCTION

The rate increasing population in our country has increasing rapidly and also, we have increase in garbage which have increased environmental issue. Dustbin is a container which collects garbage's or stores items which recyclable or non-recyclable, decompose and non- decompose. They are usually used in homes, office etc, but in case they are full no one is there to clean it and the garbage are spilled out. The surrounding of a dustbin is also conducive for increasing the pollution level [2]. Air pollution due to a dustbin can produce bacteria and virus which can produce life harmful diseases for human. Therefore, we have designed a smart dustbin using ARDUINO UNO, ultrasonic sensor which will sense the item to be thrown in the dustbin and open the lid with the help of the motor. It is an IOT based project that will bring

a new and smart way of cleanliness. It is a decent gadget to make your home clean, due to practically all offspring of home consistently make it grimy and spread litter to a great extent by electronics, rappers and various other things. Since the smart dustbin is additionally intriguing and children make fun with it so it will help to maintain cleanliness in home. It will be applied for various type of waste. Dustbin will open its lid when someone/object is near at some range then it will wait for given time period than it will close automatically. Here lid will close when you don't want to use and it will only open when it required.as well as inside the city with keeping all security aspects in mind. These systems will also help us in waste management. The authorities would also have a track record of each and every user which would help them to monitor the cleanliness in the city user which would help them.

II. RELATED WORK

Longhi S. had made a quantitative analysis between previous as well as existing dustbins and their serving population. They studied and analyzed the spatial distribution of dustbins in the local areas of Dhaka city using the average nearest neighboring function. Significantly, the spatial circulation of the current dustbins had appeared to be dominant in the clustered pattern. Next, an optimal number of additional dustbins were calculated. It was shown that the number of existing dustbins was insufficient in the studied area. [1]

Thakker S. and Narayanamoorthi R. used ultrasonic sensors in dustbins, which were used to determine its fill status. The dustbin was divided into three levels of garbage. The sensors, detects dustbins filled status. This data was sent using GSM module. They used three ultrasonic sensors at three different levels in the dustbin; this increases cost also the sensors could be damaged by harsh use by the users. In a Smart Garbage

System (sgs), battery-based smart garbage bins (sgbs) they exchange information with each other using router and server collects this information and this information is analyzed for service provisioning. This includes various IOT skills for user convenience and it increases the battery life with the help of two types of energy-efficient operations of the sgbs: standalone operation and cooperation-based operation. The proposed sgs had been experimented as a pilot project in the Gangnam district, Seoul, Republic of Korea, for a one-year period. This test demonstrated that the food waste could be decreased by 33%. [2]

Mamun M. used a camera and placed load cell sensors at base of the dustbins, at each collection point. Camera took continuous snapshots of the dustbin. A threshold level was set which compares the snapshots and load sensor. A microcontroller did the comparison. After analyses, an idea about the level of garbage in dustbin and from the load cell sensors, weight of garbage could be estimated. The controller checks, if the threshold level is exceeded or not. This was convenient to use but economically not reliable. [3]

The Indian government has started a number of smart city projects, and in order for these cities to be smarter, the garbage collection system must also be better. Furthermore, people must have simple access to garbage disposal stations and the garbage collection process. It must be cost-effective in terms of both time and fuel. The majority of Indian cities and towns are not adequately designed to permit appropriate rubbish disposal and collection. There are also cities that are fast expanding, putting strain on existing infrastructure that is not keeping up with the rate of urbanization. In our proposed system, we will use Ultrasonic Sensors, Buzzers, Arduino Boards, Moisture Sensors, and Wi-Fi Modules to check the garbage fill status of the dustbin. This will check the status and send a message to the cloud that the dustbin is full. The message will then be sent to the collection van via Wi-Fi Module, and garbage collection will take place. If the dustbin is not cleaned in a timely manner, we will send a message to higher authority, who will take appropriate action. Dry and wet rubbish, will be separated in our proposed system. As a result, the Automatic Garbage Fill Alerting system improves garbage collection efficiency, making our trash cans and towns smarter at the same time. [4]

The city's cleanliness is maintained through a variety of initiatives taken by the municipal government. One of them is the installation of dustbins, for the public's convenience to dispose goods at a fixed distance. Garbage collection is an important municipal job that is linked to health concerns. We created a model for a 'Smart Dustbin,' which displays information on the contents of the bin. The waste has filled the dustbin to a certain level, and cleaning or emptying it is a matter of urgency concern. This eliminates the habit of dumping trash in a roadside bin, which results in a nasty smell and illness among the populace. The single directional cylinder is featured in the smart dustbin's design. [5]

Ultrasonic sensors are ideal for mobile robots since the systems are simple and straightforward to operate. The map of the environment should include information about the reflection properties of objects when a mobile robot navigates using an ultrasonic sensor. A vector expression map is preferable than a grid map for this purpose. This research proposes a vector map-based environment reconstruction approach. The environment is reconstructed from data received by our unique ultrasonic sensor, which can sense the normal direction of walls, and the next sensing site is automatically identified in this technique. The experimental results of constructing a map with this approach are displayed. As a consequence of the studies, it was discovered that this method can be used to measure walls, and the usefulness of the planning algorithm for the sensing point was confirmed. [6]

Although pyroelectric infrared (PIR) sensors are commonly utilized as a presence trigger, the analogue output of PIR sensors is affected by a number of factors, including the distance between the body and the PIR sensor, the direction and speed of movement, as well as the body form and gait. An empirical investigation of human movement detection and identification utilizing a collection of PIR sensors is presented in this work. We created a data gathering module with two pairs of orthogonally aligned PIR sensors and modified Fresnel lenses. Three PIR-based modules have been installed in a hallway to monitor people: one on the ceiling, and two on opposing walls facing each other. We have collected eight subjects of data set. When walked in three distinct directions (back and forth), three distance intervals (near to one wall

sensor, in the middle, close to the other wall sensor), and three speed levels (slow, moderate, fast). We employed a raw data set and a reduced feature set comprising of amplitude and time to peaks, as well as passage duration derived from each PIR sensor. We used well-known machine learning algorithms, such as instance-based learning and support vector machine, to do classification analyses. Our findings demonstrate that we could determine the direction and speed of movement, the distance interval, and identify persons with more than 92 percent accuracy using raw data from a single PIR sensor in each of the three modules. Using the reduced feature set recovered from two pairs of PIR sensors in each of the three modules, we were able to obtain more than 94 percent accuracy in classifying direction, speed, and distance, as well as identifying people. [7]

DC motors can be used in a variety of settings, from industrial to domestic. For optimal output, such as pace of production, numerous parameters must be addressed in industrial applications. Smoother operation, controllable torque, and the use of a single system for several operations are all advantages of DC motor speed and orientation control. This study presents a method for controlling the speed of a DC motor wirelessly for use in industrial applications. A transmitter generates control signals that are wirelessly relayed to the receiver. The receiver controls the speed of the DC motor provided by Pulse Width Modulation based on the control signals (PWM). RF wireless module Zigbee is used to convey the control signals. The DC Motor's speed may now be regulated wirelessly through a control room, ensuring the system's long-term viability. [8]

Apart from AC motor systems, DC motor systems have played an essential role in the advancement and growth of the industrial revolution, making them the heart of a variety of applications. As a result, the creation of a more efficient control strategy for controlling a DC servomotor system, as well as a well-defined mathematical model for off-line simulation, is critical for this sort of system. Nonlinear characteristics and dynamic factors in servomotor systems, such as backlash, dead zone, and Coulomb friction, make them difficult to regulate using traditional control methods like PID controllers. The dynamics of the servomotor, as well as external influences, contribute to the

complexity of the system analysis, such as when the load coupled to the control system changes. In order to overcome the complicated problems linked to the regulation of these nonlinear systems, new intelligent control approaches such as Neural Networks, evolutionary algorithms, and fuzzy logic methods are being investigated. To implement the control system in this study, we used a combination of two multilayer neural networks: a) the first network is used to build a model that mimics the function of a DC servomotor system, and b) the second network is used to implement the controller that uses back propagation learning to control the operation of the model network. The proposed combination of the two neural networks will be able to handle the nonlinear parameters and dynamic elements included in the original servomotor system, resulting in proper output speed and position control. To display final findings and compare them to conventional PID controlled results for the same model, an off-line simulation using the MATLAB Neural Network toolkit is utilized. [9]

The RFID-based Smart Dustbin System is a model of the next-generation dustbin, which will be heavily fitted with sensors. The security considerations are the primary focus of this model. Some of the bombs detonated in Delhi's garbage cans during the 2008 serial explosions. Following the blasts, all of Delhi's metro stations were devoid of trash cans. This is due to the fact that explosives may be easily stored in dustbins. We provide a feasible solution for metro station trash cans in this study. We used RFID tags, an RFID reader, an ultrasonic sensor, geared motors, servo motors, an Arduino UNO, a Raspberry Pi, and a solar panel to power this prototype model of the smart dustbin system. For waste monitoring, the system uses a cloud-based monitoring system. There is no need to check the dustbins on a regular basis when using a cloud-based system. We use a tiny solar panel for power supply to keep the system eco-friendly and maintain the metro's carbon neutral impact. [10]

For industries and businesses, there has been an increase in need for secure systems that are trustworthy and responsive. RFID (Radio Frequency Identification) is a reliable and quick way to identify materials. Barcodes were once preferred over RFID because of their lower cost, however RFID is now more widely available and easier to use. Because of the replacement

of microcontroller with arduino, research has produced several major modifications that make programming a lot shorter and easier. Arduino simplifies the circuit and programming. The study is based on an RFID and Arduino with GSM module-based security access and control system. For leakage detection, certain sensors such as PIR and LPG are employed. At home, workplace, and commercial buildings, a security access system is very convenient to use. Items are tracked in the manufacturing environment and are labeled in supermarkets. They're commonly regarded as a sophisticated barcode. Their potential application area, on the other hand, is considerably larger. This article discusses RFID-based applications such as access control, position tracking, and simple charging, among others. RFID tags are predicted to number in the billions in the future years, but they're still regarded like barcodes, with little regard for the privacy implications of this modern technology. [11]

III. PROPOSED SYSTEM

A. Proposed Statement

To monitor the cleanliness in the city These systems will help us to keep our environment clean near the Public areas.

B. Block Diagram

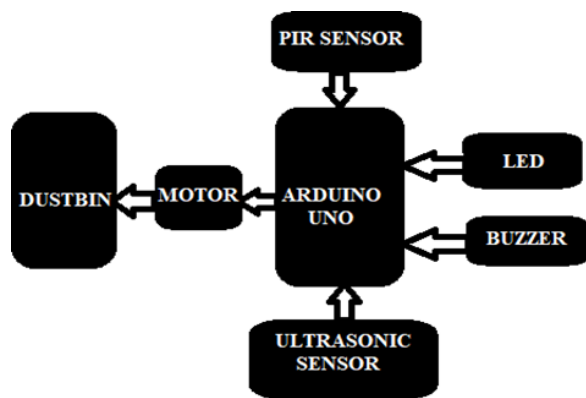

Fig. 1 System Block Diagram

IV. COMPONENTS

A. Power Supply

The elementary unit of any electronic system is the power supply which provides required power for

system's operation. In this project +5V supply is used for Arduino, Bluetooth module and relay module.

B. Arduino Uno

The Arduino UNO[3] is a microcontroller board on the ATmega 328p. it has 14 Digital input/outputpins (of which 6 can used as PWM outputs), 6 analogs Inputs, a 16 MHz crystal oscillator, a USB connection, a power jack, an ICPS Header, and a reset button. it contains everything needed to support the Microcontroller[4] simply connect it to a computer with a USB cable or power it With a Ac to Dc adapter or battery to get started. The UNO differs from all preceding boards in that it does not use the FTDI USB-to- Serial driver chip. Instead it features the Atmega 8U2 programmed as USB-to-Serial converter.



Fig. 2. Arduino Uno

C. Ultrasonic Sensor

The HC-SR04 Ultrasonic Distance Sensor[5] is a sensor used for detecting the distance to an object using sonar. It is a device that is used to measure the distance between a particular object from the sensor. It has a transmitter which transmits sound wave and a receiver that receives the same signal. The concept of calculation of distance behind this sensor is very simple. It basically calculates the time taken by the signal to come back after reflection from the object, multiplies it with speed of sound and then divides it with 2 as the signal is travelling double distance i.e. going towards the object and coming back from that object. Here we are using this sensor to find the distance between the garbage and the lid of the bin. So, as the bin starts filling the distance between the garbage and the lid would start to decrease, and when it will cross a certain level the micro controller would send the data regarding clearing the garbage from the bin to the cloud server which can be easily forecasted on the frontend with the help of an app or a webpage.



Fig. 3. Ultrasonic Sensor

D. PIR Sensor

The PIR sensor [6] stands for Passive Infrared sensor. It is a low cost sensor which can detect the presence of Human beings or animals. This sensor has three output pins Vcc, Output and Ground as shown in the pin diagram above. Since the output pin is 3.3V TTL logic it can be used with any platforms like Arduino, Raspberry, PIC, ARM, 8051 etc.

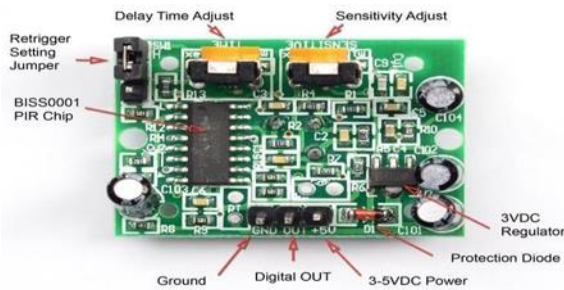

Fig. 4. PIR Sensor

E. Servo Motor

A servo motor [7] is an electrical device which can push or rotate an object with great precision.

V. SOFTWARE DETAILS

A. Algorithm

- Step 1: Start
- Step 2: Input to, PIR sensor
- Step 3: If distance is \leq predefined value Then servomotor ON and opens lid
- Step 4: End If Lid will remains closed
- Step 5: If distance from the garbage to the sensor \geq predefined value, Then, BuzzerON
- Step 6: End

B. Flowchart

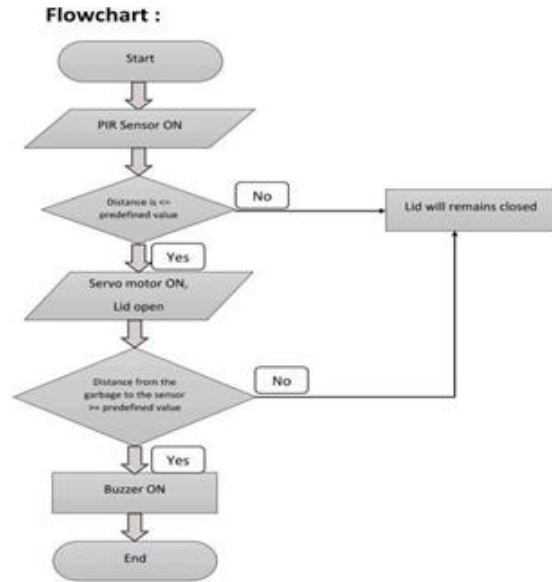

Fig. 5. System Flowchart

C. CIRCUIT DIAGRAM

In the wake of setting up the Dustbin and making all the crucial affiliations, move the code to Arduino. At the point when the system is energized ON, Arduino keeps checking for any article near the Ultrasonic Sensor. If the Ultrasonic Sensor perceives any article like a hand for example, Arduino figures its detachment and if it not actually a certain predefined regard, The Motor of Servo of Arduino Uno will be instigated with the help of broad arm, it will lift the top open. By then normally buzzer starts sounding. After certain time, the spread is in this manner closed and buzzer sound is ended.

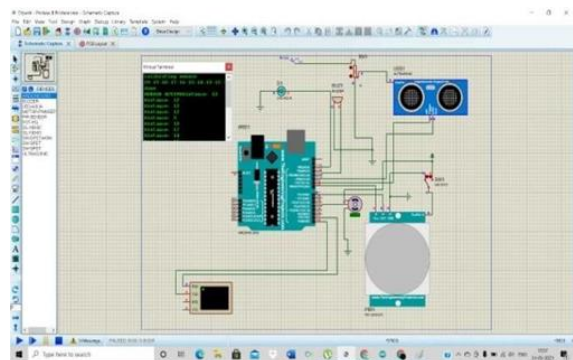

Fig. 7. Circuit Diagram with Simulation

VI. CONCLUSION

An Arduino Uno based automatic lid opened dustbin system is developed for smart monitoring and clearance of the garbage. The system developed here

is used often for regular clearing of the garbage in premises. And also, helpful to maintain surroundings clean. Thus, this system comes in handy as good and appreciable solution in environmental monitoring. At last it becomes an efficient system for clearing dust.

VII. FUTURE SCOPE

The future enhancement of this dustbin can be done by connecting this dustbin to the cloud and stores that who threw the garbage in the dustbin using RFID reader and RFID Tags for safety purpose. The dustbin contains electrical wires, when liquid garbage is thrown into the dustbin it may lead to short circuit, the future work can be done by using liquid detecting sensors and avoids throwing liquid garbage into the dustbin.

REFERENCES

- [1] Longhi, S., Marzioni, D., Alidori, E., Buo, G. D., prist, M., Grisostomi, M., Pirro, M. Solid Waste management Architecture using Wireless Sensor Network Technology in New Technologies, Mobility and Security (NTMS), 5th International Conference, IEEE, pp. 1-5, 2007.
- [2] Thakker, S., Narayanamoorthi, R., Smart and Wireless Waste Management, in Innovation in Information, Embedded and communication systems (ICIIECS), pp. 1-4, 2009.
- [3] Al Mamun, M. A., Hannan, M. A., Hussian, A., Real time Solid Waste Bin Monitoring System Framework using Wireless Sensor Network in Electronics, Information and Communications (ICEIC), International conference, IEEE, pp.1-2, 2010.
- [4] Bikramjit Singh and Manpreet Kaur, "Smart Dustbins for Smart Cities", International Journal of Computer Science and Information Technologies, Vol. 7, No. 2, pp. 610-614, 2016.
- [5] Twinkle Sinha, Mugesh Kumar and P. Saisharan, "Smart Dustbin", International Journal of Industrial Electronics and Electrical Engineering, Vol. 3, No. 5, pp. 101-104, 2015
- [6] A. Ohya; Y. Nagashima; 1994 IEEE International Conference on Robotics and Automation, "Exploring unknown environment and map construction using ultrasonic sensing of normal direction of walls".
- [7] Jaeseok Yun, Sang-Shin Lee; "Human Movement Detection and Identification Using Pyroelectric Infrared Sensors" Year 20148057-8081; doi:10.3390/s 140508057; ISSN 1424-8220.
- [8] Jeetender Singh Chauhan, Sunil Semwal, "" International Journal of Engineering Research and Applications (IJERA) ISSN: 2248-9622, Vol. 3, Issue 1, January -February 2013.
- [9] Yahia Makableh, Georgia Southern University, "Efficient Control of DC Servomotor Systems Using Backpropagation Neural Networks" Spring 2011.
- [10] A. Tripathi, C. Pandey, A. Narwal and D. Negi, "Cloud Based Smart Dustbin System for Metro Station", Proceedings of 3rd IEEE International Conference on Internet of Things: Smart Innovation and Usages, pp. 1-8, 2018.
- [11] Grewal Kaushal, "RFID Based Security and Access Control System Using Arduino with GSM Module" IJEEE, Vol. 2, Issue 2 April, 2015 e-ISSN: 1694-2310 | p-ISSN: 1694-2426