

Security Surveillance System with Email Notification Using Raspberry Pi

NKOLIKA O. NWAZOR¹, STELLA IFEOMA ORAKWUE²

^{1,2} *Electrical/Electronic Engineering Department, University of Port Harcourt, Nigeria*

Abstract- *Security is one of the major concerns of man after food and shelter. The video security surveillance system proposed in this work hinges on the integration of cameras and raspberry pi zero microcontrollers into an alert system. Raspberry Pi operates video cameras which stream live video and allows for access to real-time events. This work is focused on developing a security surveillance system that detects the intrusion of humans and responds speedily by capturing and relaying images to owner-based wireless modules. The Raspberry Pi Zero microcontroller was programmed using functions found in Open CV. This Raspberry Pi-based Smart Surveillance System presents the idea of monitoring a particular place in a remote area. The proposed solution is a cost-effective surveillance system, which is efficient and easy to implement.*

Indexed Terms- *security, surveillance, raspberry pi, motion detection, open CV, e-mail notification*

I. INTRODUCTION

Security is one of the major concerns that affect our day-to-day life. Everyone wants to be secure. Recently, the world has experienced an exponential increase in crime rate. Criminals break into houses daily around the world carting away huge amounts of money and precious items. Sensitive and confidential documents, materials and equipment in corporations are constantly declared missing from where they are kept. So there is a need to provide a device that can detect unauthorized persons in an environment. Surveillance involves monitoring behaviour, activities, or other changing information for the purpose of influencing, managing, directing, or protecting. This involves observation from a distance by means of electronic equipment or interception of electronically transmitted information (i.e. internet traffic or phone calls).

In recent years, there has been an increase in video surveillance systems in public and private environments due to a heightened sense of security [1, 2]. The next generation of surveillance systems will be able to annotate video and locally coordinate the tracking of objects while multiplexing hundreds of video streams in real time. Video surveillance systems play an increasingly important role in the maintenance of social security. It has been widely used in many settings such as finance, public security, banking and homes. Traditional video surveillance can generally achieve close-distance monitoring by using the PC as a monitor host connected to a monitor camera with a coaxial cable [3].

Initially, it was dominated by analog cameras connected using coaxial cables. For cost and performance reasons, there was a change in preference for digital switching systems and now IP-based delivery of data [1]. Detection and tracking of moving objects are important tasks for computer vision, particularly for visual-based surveillance systems. Video surveillance application, most times requires the system to monitor a wide area, so multidirectional cameras or mobile cameras are generally used [4].

Commercial spaces, universities, hospitals and factories require video capturing systems that have the ability to multitask objectives such as alerting and recording live video of an intruder. The advancements in video surveillance technology have made it possible to view your remote security camera from any internet-enabled PC or smart phone from anywhere in the world. This encompasses the use of CCTV (DVRs) systems and IP cameras. This technology is impressive but the price of implementation has proven to be an obstacle, especially for a small home application.

Therefore, new technology in this aspect revolves around the affordability of a product in terms of its price and ease of implementation. The Raspberry Pi encompasses both criteria in its cheapness and effectiveness as a computer which can be interfaced with other modules to realize systems with great functionality. A lot can be done on it ranging from motor speed control, automatic lighting, VPN server, security systems etc. This project is an application of the latter.

The Raspberry Pi microcomputer is capable of implementing cost-effective security system for various applications. This new arising technology related to security provides a comfortable and safe environment for small homes. The various objectives of the system are to detect an intruder, take an image of the intruder and also convey an alert message to the owner via output devices. In doing so it thus allows for remote monitoring of homes from anywhere in the world. The system proposed in this work cannot wholly replace the role of CCTV and IP surveillance cameras, especially in large commercial set-ups but will make it easy for low-income home owners to monitor their homes at a very affordable price. In addition to the fact that the Raspberry Pi board is cheap, the camera used in this project is cheaper compared to the others. The whole system is straightforward and easy to implement.

II. LITERATURE REVIEW

Security is the state of being protected or safe from harm. It is a term that has different dimensions in psychology, public safety, defence and military matters and information access. Security and safety are always intertwined and it is impossible to design a security system without taking into account the safety of the object or person into consideration. An early model of an advanced video home security system included a large motorized camera that moved down a track to view the exterior of the home through four peepholes mounted in the front door [5]. The video camera transmitted grainy images of visitors to a stationary television monitor that also served as the control panel where the homeowner could remotely control the camera's movement [6]. The panel, which was located in a separate room away from the camera, was equipped with security

features such as the intercom to communicate with visitors, a door lock switch and an alarm button that could activate the alarm at the central system that monitors the residence [5].

Today, more advanced security systems are used by homeowners. Users can confirm that their doors are locked and alarms on by simply logging in remotely via a web-enabled device [6]. With the push of a button, they can lock doors, enable the system, or adjust the thermostat. Nowadays, there are surveillance cameras that are as small as a square inch, connected to the internet and outfitted with powerful lenses that can capture and stream high-definition video online and can be viewed from any location. Homeowners can now program their security systems to send a live video clip of an area if motion is detected when the home is unoccupied and the alarm is activated by using a connected smart home system,

Some authors have worked on security surveillance systems. The authors [8, 9], developed a real-time security system using human motion detection. The system monitors the area in which it is being deployed. In the system, the human motion detection system is achieved using a web camera. If a motion is detected, the computer will start recording, buzz an alarm and send an SMS to people listed in its database. A motion-based security system that uses a passive infrared sensor (motion sensor) was proposed by [10, 11, and 12]. When a human motion is detected the system sends an alert. The authors [13], proposed a smart surveillance system that the user can use to observe environments using an Android application. Whenever the PIR Sensor detects an intruder or new introduction it will send a signal to the raspberry pi GPIO pin. Pi senses the signal and in turn, sends the signal to the USB Camera for capturing the image. The authors [14, 15, and 16] also worked on the use of raspberry pi for security surveillance and a motion sensor to allow live streaming for her system. A system that uses a motion-activated security camera with email notifications using Raspberry Pi was proposed by [17]. The system described allows customization in that the user can turn off the motion sensor or leave it on. The author [18] worked on low-cost wireless image acquisition and transfer to web clients using Raspberry Pi for remote monitoring. A

wi-Fi-controlled raspberry pi home security system was proposed by [19]. The major limitation of some of the previous systems is how conspicuous they are and they can be easily spotted by a bugler. They are also quite expensive when they are implemented. Moving security cameras can be a hassle and will most times require a professional technician to help with the move.

III. METHODOLOGY

The proposed system is a home security surveillance system that is capable of detecting human motion by means of a portable camera. The system is also very inconspicuous; it can be hidden in any location where the user wants to survey. The system is not as expensive as most security systems in the market. The system is lightweight and doesn't require professional help when changing the location.

For a surveillance system to be utilized for effective monitoring and alerting, the system has to have at least three functions. These functions are detection which is carried out by the camera, image processing and alert mechanism. This Raspberry Pi based security system is thus composed of mainly two parts. These are: design hardware and design software.

3.2 Design Hardware

The system design consists of four parts which are the power supply unit, the raspberry pi camera system, the control unit and the output units. The block diagram of the design of the system is shown in fig.1

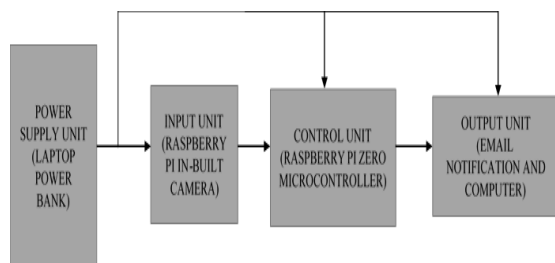

Fig 1. Block Diagram of Hardware Components

The power supply unit is made up of the power pack which supplies voltage and current to the voltage regulator (U1 and U2). The voltage regulators are

connected in parallel to increase the output current of the regulator to 2 Amp. A light emitting diode (d1) is used as a power indicator. The circuit requires a power of 10 watts. The two voltage regulators are connected in parallel to supply 10 watts. Two voltage regulators were used. Both 7805 gave 5V. From the datasheet (in appendix A) the 7805 output voltage is 5V 1A. In the parallel connection of both regulators it supplies 2A.

3.1 The input unit

The input unit is made up of the raspberry pi camera that captures the human face and sends the data to the microcontroller. The raspberry pi camera board plugs directly into the raspberry pi. It is able to deliver a crystal clear 5-megapixel resolution image to the raspberry pi zero. This camera is made specifically for the Raspberry Pi.

The control unit is the raspberry pi zero wireless module controller. The Raspberry Pi Zero is a super-small, hackable and ultra-low-cost computer. It comes with a mini-HDMI, micro-B OTG USB, and the same 40-pin GPIO. It is this microcontroller that is used to receive the image of the environment and scan if the image is same as the image stored in the controller. The system will keep checking from the input of the camera, if the image is different and once it detects a change in the environment it will send signal to the output unit.

The system uses an open CV library for the processing of the image of the individual. The open CV library makes use of the motion based algorithm. The microcontroller uses the motion algorithm method to identify motion (movement) of objects in the group of live frames. The motion is identified using contour map between frames. The difference in frames is used to find the contour. The human contour is categorized using a threshold contour size. When a human is detected it sends an E-mail to the owner and the streaming of the events can be accessed via the raspberry pi. The video of the event is sent via email to the owner of the house it is deployed. The email is sent from the output using a LAN network. The microcontroller was programmed using python language. The system works based on the algorithm and program used to control the control unit.

3.2 Output Units

The output unit is the email. The LAN network enables the system to send the video frames of the intrusion process to the user of the device. Internet connection was necessary to enable the Raspberry Pi communicate over network protocols and thus allow for installation of required Python packages. Since the broadcast router uses Dynamic Host Configuration Protocol (DHCP) to dish out IP addresses to devices connected to it, it was necessary to change the IP address of the Pi from static to dynamic. This was done by editing the network interfaces file. When the network interface file is changed, the user can then access the camera's live footage using the IP address.

3.3 Software Design

Open CV library and the python programming language were used in the command modules in the system. Open CV was used to analyze images and video files. Open CV thus provided the necessary platform to achieve image processing. The code that enables video processing is implemented using Open CV. Python Programming is a very useful programming tool that has an easy to read syntax, and allows programmers to use fewer lines of code than would be possible in languages such as assembly, C or Java. The python programming language was used to implement instructions to the microcontroller. The algorithm for the system software is shown below:

Step 1: Image capturing and transfer: The camera is capturing scenes of a fixed location. The captured frames are transferred to the Raspberry Pi controller.
 Step 2: Background subtraction: Each frame is applied with background subtraction method to get the foreground image where the motion to be identified.
 Step 3: Motion detection: Motion of objects above a standard size (small size insects, animals are not considered) are detected through a group of frames using temporal motion detection method

Step 4: Activate alert mode: If any motion belongs to predefined size or type is identified, then the alert mode is activated by a trigger to the controller.

Step 5: Alert message transfer: The Email contents are created with the consecutive frames where motion was detected. Then the API command is activated to send the Email to the receiver. After sending Email to the user the captured image is stored in the local storage.

3.3.2 Flowchart for System Process

The flowchart in fig.2 shows the processes taken by the Raspberry Pi Controller when an intruder is detected to the email notification point. The algorithm begins with system initialization through the capturing process by the Raspberry Pi Camera all the way to the check for internet connectivity. The systems will then generate and send an email based on the foreground and background image. The raspberry Pi generates the email which it sends to the user of the system.

IV. RESULTS AND DISCUSSION

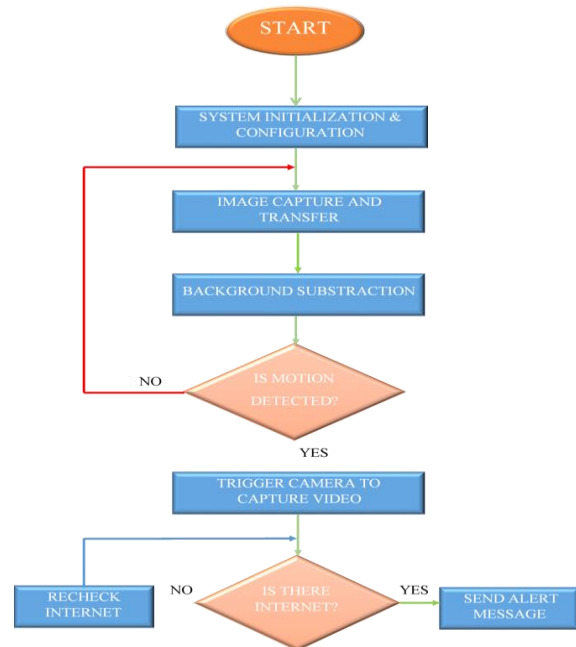

Fig 2: Flowchart of the system.

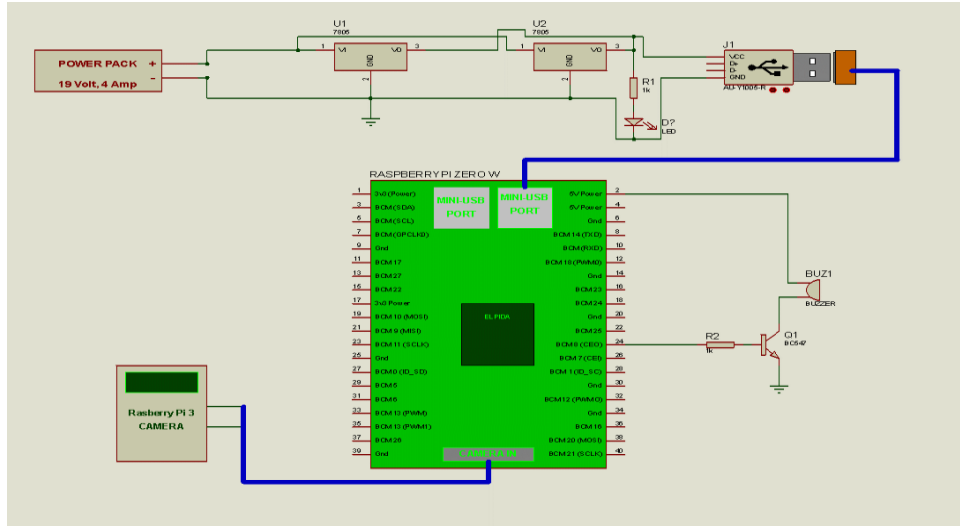

Fig.3: The Circuit Diagram of the Entire Hardware

The circuit diagram of the proposed system is shown in fig.3. The system was analysed and the circuit was designed in an electrical drawing studio (Proteus version 7.8) environment. This was used to simulate some of the parts of the circuit to show if the design will work.

CONCLUSION

This project was all about the design and construction a system that can be able to detect when an intruder enters an area and sends the picture and video files of the event to the owner. The system utilizes the Raspberry Pi Zero microcontroller and was programmed using the python-language and the Open CV library. The system worked satisfactorily and as expected. Summarily this system allows for faster transmission of the intruder alert, can be assessed from anywhere and anytime and is an economical means of surveillance.

REFERENCES

[1] Kandhalu, A., Rowe, A., Rajkumar, R., Huang, C. and Yeh, A.,(2009). Real-Time Video Surveillance over IEEE 802.11 Mesh Networks, IEEE Explore, Real-Time and Embedded Technology and Applications Symposium, 2009 (RTAS 2009) 15th IEEE, 205-214.

[2] Jyothi, S. and Vardhan, K.(2016), Design and implementation of real time security surveillance system using, 2016 International Conference on Communication and Electronics Systems (ICCES) IoT 1-5, doi: 10.1109/CESYS.2016.7890003

[3] Mamindla, K., Padmaja, V. and NagaDeepa, C.H.,(2013), Embedded Real Time Video Monitoring System using Arm. IOSR Journal of Engineering 3(7),14-18, doi:10.9790/3021-03761418

[4] Martinel N, Foresti GL, Micheloni C., (2016), Person Reidentification in a Distributed Camera Network Framework. IEEE Trans Cybern. 47(11):3530-3541. doi: 10.1109/TCYB.2016.2568264

[5] Raghavale, RS (2018) "A Literature Survey on Smart Home Automation Security." International Journal of Computer Networks and Communications Security, 6(1), 1-8.

[6] Lynn, A.D & Anne, L.O. (2009): RFID and Application Security, Journal of Research and Practice in Information Technology, Vol. 41(3), pp 209-221.

[7] Anubala, B., Rahini, M. & Bavithra, T. (2014): Intelligent Door Locking System. International Journal of Engineering Research and Applications (IJERA) ISSN: 2248-9622 International Conference on Humming Bird, pp 50-53.

- [8] Ravipati, V.K.C. and Thonduri, V. (2017), An IOT Approach for Motion Detection Using Raspberry Pi. *International Journal of Innovative Science and Research Technology*, 2(7); 225-228
- [9] More, A., Monisha, S., Sahithi, P and Vittal, V. (2018), Wireless Home Security Surveillance System Using Android Application. 3rd National Conference on Image Processing, Computing, Communication, Networking and Data Analytics. 115-122. 10.21467/proceedings.1.19.
- [10] Thu, M.M., Swe, S.S. and Zaw, T.T. (2020). Security System with PIR Sensor, *Iconic Research and Engineering Journals*, 4 (6); 77-82.
- [11] Surantha, N. and Wicaksono, W. R. (2018) Design of Smart Home Security System using Object Recognition and PIR Sensor, *Procedia Computer Science, Elsevier 3rd International Conference on Computer Science and Computational Intelligence 2018*. 135:465-472. DOI: 10.1016/j.procs.2018.08.198
- [12] Nepal, G., Biswa, R., Adhikari, D., Chodon, P., Gyeltshen, S., and Chenchu, (2013), Passive Infrared (PIR) Sensor Based Security System. *International Journal of Electrical, Electronics and Computer Systems*. 14 (2)
- [13] Priya, B.P. and Viraj, M.C. (2016), Smart Motion Detection System using Raspberry-Pi, *International Journal of Applied Information System (IJ AIS)* 10; 37-40.
- [14] Sunil, K. and Rahul, R. (2016), An Internet of Things approach for motion detection using Raspberry-Pi, *International Journal of Advanced Technology and Innovative Research* 8:3622-3627.
- [15] Aamir, N.Z. and Mohamed, S. (2015) An Internet of Things approaches for motion detection using Raspberry-Pi, *International Conference on intelligent computing and Internet of Things (ICIT)*.
- [16] Al-Rawi, M., Abdulhamid, M. and Sheshai, S. (2019), Design of Security System Based on Raspberry-Pi, *The Scientific Bulletin of Electrical Engineering Faculty* 19(2); 56-61. DOI: 10.1515/sbeef-2019-0022
- [17] Muruti, G., Rahim, F. A., Zawawi, N.A. (2018), Motion Activated Security Camera Using Raspberry Pi: An IoT Solution for Room Security. *Journal of Computational and Theoretical Nanoscience* 24(3):1698-1701. DOI: 10.1166/asl.2018.11140
- [18] Kumar, U., Manda, R., Sai, S. and Pammi, A. (2014). Implementation of Low-Cost Wireless Image Acquisition and Transfer to Web Client Using Raspberry Pi for Remote Monitoring. *The International Journal of Computer Networking, Wireless and Mobile Communications (IJCNWMC)* 4(3); 17-20.
- [19] Ukey, P., Shinde, A., Kasrung, S., Kamble, S., Kadu, J. (2017), Development of Smart Home Security System using Raspberry-Pi, *International Research Journal of Engineering and Technology (IRJET)*. 4(6); 1926-1928