

IOT-Based Monitoring of Electrical Substation Parameters

DR. CH. RAMBABU, M.E, PH. D¹, MUTYALA NAGENDRA KUMAR², NALLAPU SUNEEL³,
KESAVARAPU SUMANTH⁴

¹Professors, Department of Electrical and Electronics Engineering Vasireddy Venkatadri Institute of Technology, Ap, Guntur, India

^{2, 3, 4} Student, Department of Electrical and Electronics Engineering Vasireddy Venkatadri Institute of Technology, Ap, Guntur, India

Abstract- The reliable operation of electrical substations is essential for maintaining stability and continuity in power systems. This paper presents an IoT-based monitoring system designed to observe critical substation parameters such as voltage, current, temperature, frequency, and power in real time. The proposed system integrates sensors with a microcontroller (Arduino/ESP8266) to collect data continuously and transmit it to a cloud platform using Wi-Fi communication. The monitored data is displayed locally on an LCD and remotely through a web or mobile interface, enabling efficient supervision without physical presence. The system also provides timely detection of abnormal conditions, supporting preventive maintenance and reducing the risk of equipment failure. Experimental results demonstrate that the system accurately measures parameters under varying load conditions and updates them continuously to the cloud. The graphical visualization of data further aids in performance analysis and fault identification. Overall, the proposed solution enhances reliability, reduces manual intervention, and contributes to the development of smart and efficient power system monitoring.

Index Terms- IoT, Substation Monitoring, Real-Time Monitoring, Arduino/ESP8266, Cloud Computing, Smart Grid

I. INTRODUCTION

The reliable operation of electrical power systems is essential for ensuring continuous and stable electricity supply in modern society. Electrical substations play a critical role in power transmission and distribution by performing functions such as voltage transformation, switching, and protection. However, with the increasing demand for electricity, rapid industrialization, and integration of advanced technologies, the complexity of power systems has

significantly increased. This necessitates efficient monitoring and control mechanisms to ensure system reliability, safety, and performance.

Traditionally, substation monitoring has relied on manual inspection and conventional measuring instruments, which are time-consuming, less accurate, and incapable of providing real-time data. Such methods often lead to delayed fault detection and increased risk of equipment failure. To overcome these limitations, modern monitoring systems have incorporated advanced technologies such as the Internet of Things (IoT), enabling automated and real-time monitoring of substation parameters [1], [3].

IoT-based systems utilize sensors, microcontrollers, and communication networks to continuously collect and transmit data related to critical parameters such as voltage, current, temperature, frequency, and power. This data is sent to cloud platforms, where it can be analyzed and visualized through web or mobile interfaces. The integration of IoT in power systems not only enhances monitoring accuracy but also enables remote access, allowing operators to supervise substations from any location [4], [5]. Furthermore, IoT facilitates early detection of abnormal conditions, reducing maintenance costs and preventing major system failures.

Recent research has highlighted the effectiveness of IoT in improving substation monitoring and control. For instance, industrial IoT-based solutions have been developed to enhance operational efficiency and reliability of substations [1]. Similarly, IoT frameworks integrated with smart grids and renewable energy systems have demonstrated

improved energy management and system flexibility [2]. Real-time monitoring and control systems using IoT have also been proposed to ensure continuous observation of substation parameters and timely response to faults [6], [7].

Despite these advancements, there is still a need for cost-effective, efficient, and easy-to-implement monitoring systems that can provide real-time data and ensure reliable operation of substations. In this context, this paper presents an IoT-based monitoring system designed to continuously observe key electrical parameters using sensors and a microcontroller. The collected data is transmitted to a cloud platform via Wi-Fi, enabling remote monitoring and analysis.

The proposed system aims to enhance the reliability, efficiency, and safety of electrical substations by providing real-time monitoring, reducing human intervention, and enabling quick fault detection.

II. RELATED WORK

Recent advancements in Internet of Things (IoT) technology have significantly transformed the monitoring and control of electrical substations. Several researchers have proposed IoT-based systems to enhance real-time monitoring, improve operational efficiency, and reduce manual intervention in power systems.

Verma et al. [8] presented an IoT-based framework for substation monitoring and control within smart grid environments. Their work highlights the integration of sensors and communication technologies to achieve efficient data acquisition and remote supervision. Similarly, Sai Kiran et al. [9] developed a system that monitors substation parameters such as voltage and current while also enabling control operations, demonstrating the effectiveness of IoT in maintaining system stability.

Mohammed et al. [10] proposed an IoT-based monitoring and management system for substations, focusing on real-time data acquisition and cloud-based storage. Their approach enables remote monitoring and improves system reliability. Rehman et al. [11] implemented an Arduino-based IoT system

with data logging capabilities, which records substation parameters and allows historical data analysis. This enhances fault detection and maintenance planning.

Lakshmi et al. [12] designed an IoT-based substation monitoring system that continuously tracks electrical parameters and provides alerts during abnormal conditions. Their system emphasizes real-time monitoring and improved safety. Similarly, Kalpana et al. [13] developed a real-time monitoring and control system using IoT, which enables quick response to faults and reduces downtime in substations. Sathish and Ramraj [14] also proposed a similar system focusing on automation and remote accessibility, highlighting the advantages of IoT in minimizing human intervention.

Deore et al. [15] introduced an IoT-powered substation surveillance system that enhances monitoring capabilities by integrating multiple sensors and communication technologies. Their work focuses on improving system security and operational efficiency. More recently, Raghuvamsi et al. [16] proposed an advanced system integrating IoT with Convolutional Neural Networks (CNN) for intelligent monitoring and fault prediction. This approach demonstrates the potential of combining IoT with artificial intelligence for predictive maintenance and improved reliability.

Padmashini et al. [17] provided a comprehensive overview of IoT-based monitoring systems for substations in smart grid environments. Their work discusses the role of IoT in enabling real-time data collection, remote access, and efficient energy management, emphasizing its importance in modern power systems.

Although significant progress has been made in IoT-based substation monitoring, several research gaps still exist. Many existing systems focus primarily on either monitoring or control, but lack a simple and cost-effective integrated solution that can monitor multiple critical parameters simultaneously. Some approaches involve complex architectures or advanced technologies such as artificial intelligence, which may increase system cost and implementation complexity. Additionally, not all systems provide

continuous real-time data visualization along with user-friendly interfaces for remote monitoring.

Furthermore, certain studies emphasize data logging and cloud storage but do not provide immediate alert mechanisms for abnormal conditions. In some cases, hardware implementations are not clearly demonstrated, limiting practical applicability. There is also a need for systems that can be easily deployed in small and medium-scale substations with minimal infrastructure requirements. To address these gaps, the proposed work focuses on developing a simple, cost-effective, and efficient IoT-based monitoring system that continuously measures key electrical parameters such as voltage, current, temperature, frequency, and power. The system provides real-time data transmission to a cloud platform, along with local display and remote access capabilities. This approach ensures improved reliability, quick fault detection, and reduced manual effort, making it suitable for practical substation monitoring applications.

III. MATERIALS AND METHODS

A) Proposed System Overview

The proposed system is an IoT-based monitoring solution designed to continuously observe critical electrical parameters of a substation in real time. The system integrates sensors, a microcontroller, communication modules, and a cloud platform to enable efficient data acquisition, transmission, and visualization. Parameters such as voltage, current, temperature, frequency, and power are measured using appropriate sensors and processed by the microcontroller (Arduino/ESP8266). The processed data is transmitted to a cloud server through a Wi-Fi communication module, enabling remote monitoring through a web or mobile interface. In addition, the system provides local visualization of parameters using an LCD display, allowing on-site monitoring. The continuous data flow ensures that any abnormal condition can be detected at an early stage, improving system reliability and reducing the risk of equipment failure.

BLOCK DIAGRAM

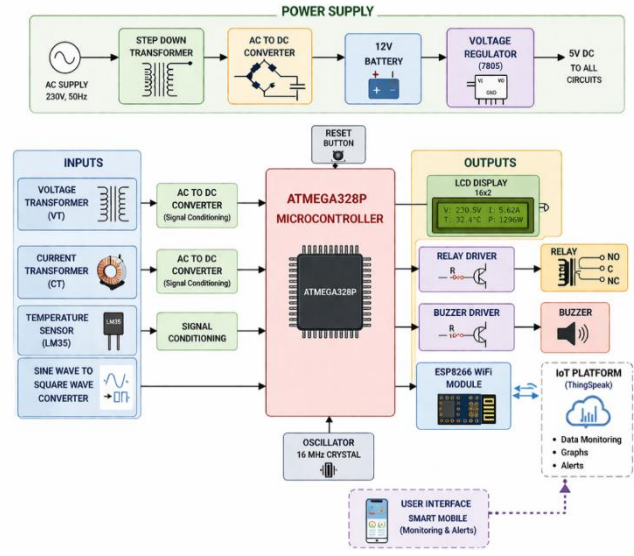

Fig.1 Block Diagram of IoT-Based Substation Monitoring System

Fig. 1 shows the block diagram of the proposed IoT-based substation monitoring system. It illustrates the interaction between sensing units, processing unit, communication module, cloud platform, and user interface. This architecture enables real-time monitoring, remote accessibility, and efficient management of substation operations.

B) System Architecture

The proposed IoT-based substation monitoring system is designed using a layered architecture to enable efficient data acquisition, processing, transmission, and visualization. It consists of five main layers: sensor layer, microcontroller layer, communication layer, cloud layer, and user interface layer.

The sensor layer collects real-time data from the substation using sensors for parameters such as voltage, current, and temperature. These signals are processed by the microcontroller layer, where an Arduino or ESP8266 converts them into meaningful values and coordinates system operations.

The communication layer uses a Wi-Fi module (ESP8266) to transmit the processed data to the cloud platform. The cloud layer stores and displays the data

in graphical and numerical formats using IoT platforms such as ThingSpeak or Blynk, enabling continuous monitoring and analysis.

The user interface layer provides both local and remote access through an LCD display and web or mobile dashboards. The overall data flow follows: Sensors → Microcontroller → Wi-Fi → Cloud → User Interface, ensuring real-time monitoring, quick fault detection, and improved system reliability.

C) Hardware Design

The hardware design of the proposed system consists of various components that work together to monitor substation parameters and ensure reliable operation. The system integrates a microcontroller, sensors, display units, and alert mechanisms for effective data acquisition and monitoring. The overall hardware connections and interfacing of components are illustrated in Fig. 2, which shows the circuit diagram of the proposed IoT-based substation monitoring system.

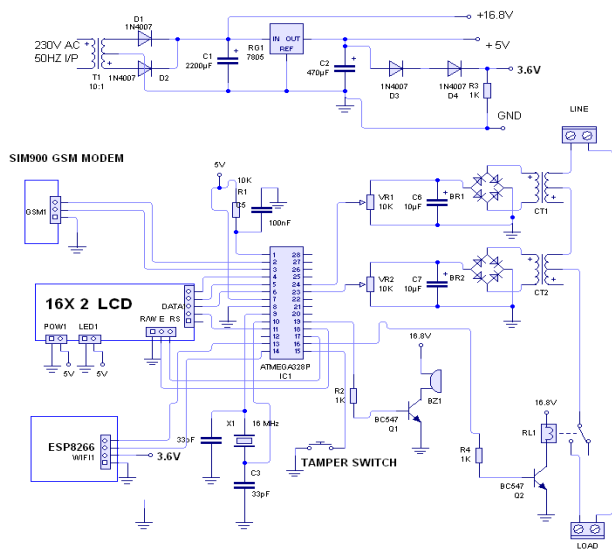

Fig. 2: Circuit Diagram of the Proposed Monitoring System

a) Microcontroller: The microcontroller serves as the central unit of the system, responsible for processing and controlling all operations. In this project, Arduino or ESP8266 is used as the main controller. It reads input data from sensors, converts analog signals into digital values, and processes them into

meaningful parameters. The microcontroller also manages communication with the Wi-Fi module to transmit data to the cloud platform. Due to its simplicity, low cost, and ease of programming, it is widely used in IoT-based applications.

b) Sensors: Sensors play a crucial role in measuring electrical and environmental parameters within the substation.

Voltage Sensor: The voltage sensor is used to measure the system voltage. It steps down high voltage levels to a safe range that can be read by the microcontroller, enabling monitoring of overvoltage and undervoltage conditions.

Current Sensor (ACS712): The current sensor measures the flow of current in the circuit. It provides an analog output proportional to the current, which helps in detecting overload conditions and analyzing power consumption.

Temperature Sensor (DHT11 / LM35): The temperature sensor monitors the temperature of substation equipment. An increase in temperature indicates possible overheating, which may lead to equipment damage if not controlled.

Frequency Sensing: The frequency sensing unit measures the system frequency, which is an important parameter for maintaining power system stability. Any deviation from the standard frequency indicates imbalance in the system.

c) Display and Alert System

The system includes a display and alert mechanism to provide real-time information and warnings.

LCD Display: A 16x2 LCD display is used to show real-time values of parameters such as voltage, temperature, frequency, and power. It provides a local interface for users to monitor system conditions directly at the substation.

Buzzer and Relay: A buzzer is used to generate an audible alert when abnormal conditions such as overvoltage or high temperature are detected. A relay driver circuit is used to control connected loads and

provide protection by disconnecting the system during fault conditions.

Overall, the hardware components are integrated to ensure continuous monitoring, accurate data acquisition, and immediate response to abnormal conditions in the substation. The circuit connections shown in Fig. 2 demonstrate how the sensors, microcontroller, communication module, and output devices are interconnected to achieve real-time monitoring and control.

D) Software and Communication Design

The software and communication design of the proposed system plays a crucial role in acquiring sensor data, processing it, and transmitting it to the cloud for real-time monitoring. The system is implemented using Arduino programming, which enables efficient control of hardware components and seamless communication with IoT platforms.

The Arduino program is designed to continuously read data from the connected sensors, including voltage, current, temperature, and frequency. The analog signals obtained from sensors such as voltage and current sensors are converted into digital values using the microcontroller's analog-to-digital converter. These raw values are then processed and converted into meaningful units such as volts, amperes, and degrees Celsius for accurate monitoring.

After processing the sensor data, the microcontroller establishes a connection with the Wi-Fi network using the ESP8266 module. Once the connection is successfully established, the system prepares the data for transmission. The processed parameters are sent to the cloud platform using standard communication protocols such as HTTP, along with API keys for secure data transfer.

IoT platforms such as ThingSpeak and Blynk are used for data storage, visualization, and remote monitoring. These platforms display the received data in the form of graphs and numerical values, allowing users to analyze system performance in real time. The graphical representation also helps in identifying trends and detecting abnormal conditions effectively.

The entire process operates in a continuous loop. The system repeatedly performs sensor data acquisition, processing, Wi-Fi connectivity, and cloud transmission without interruption. This loop-based operation ensures that real-time data is consistently updated, enabling continuous monitoring of substation parameters and timely detection of faults.

E) Working Principle

The proposed IoT-based substation monitoring system operates on continuous data acquisition, processing, and transmission to ensure real-time monitoring. Sensors installed in the system measure key parameters such as voltage, current, temperature, frequency, and power. These sensors convert physical quantities into electrical signals, which are read by the microcontroller (Arduino/ESP8266) and processed into meaningful values.

The processed data is transmitted to the cloud platform through the ESP8266 Wi-Fi module using internet communication protocols. The cloud stores and displays the data in graphical and numerical formats, enabling continuous monitoring and analysis of system performance. Users can access this information remotely through web or mobile interfaces, while local monitoring is provided via an LCD display.

In addition, the system detects abnormal conditions by comparing parameter values with predefined limits. When deviations occur, alerts are generated using a buzzer or notification mechanism. This ensures quick response, improves reliability, and helps prevent equipment damage in the substation.

IV. EXPERIMENTAL RESULTS

A) Experimental Setup

The experimental setup of the proposed IoT-based substation monitoring system consists of integrated hardware components including an Arduino microcontroller, ESP8266 Wi-Fi module, voltage sensing circuit, current sensor, temperature sensor, frequency sensing unit, 16×2 LCD display, relay driver circuit, and buzzer. These components are assembled to continuously measure and monitor electrical parameters in real time. The microcontroller acts as the central unit, collecting

data from sensors and transmitting it to the cloud through the ESP8266 module, while the LCD provides local visualization of the measured values.

The system was tested under different load conditions using a bulb load to observe variations in voltage, temperature, frequency, and power. This setup helps in evaluating the system performance under normal and varying operating conditions.

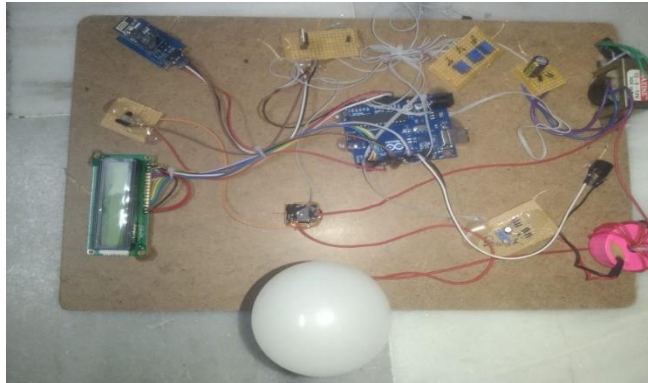

Fig.3 Complete Hardware Prototype

Fig. 3 shows the complete hardware prototype of the IoT-based substation monitoring system, illustrating the physical arrangement and interconnection of all components used for real-time monitoring and data transmission.

B) LCD Display Results

The LCD display provides a local interface for monitoring the real-time parameters of the substation monitoring system. It helps in verifying the system operation directly at the hardware level without relying on cloud connectivity. The LCD outputs are categorized into startup display and real-time parameter display.

System Startup Display: When the system is powered ON, the LCD initially displays a predefined message indicating the project title. This confirms that the microcontroller, display module, and embedded program are functioning correctly. The startup message ensures that the system has been initialized successfully and is ready to begin monitoring operations.



Fig.4 LCD Startup Display

Fig. 4 shows the LCD display during system startup, where the project title is displayed to indicate proper initialization of the system.

Real-Time Parameter Display: After initialization, the LCD continuously displays real-time values of key electrical parameters such as voltage, temperature, frequency, and power. These values are updated dynamically based on the sensor inputs, allowing users to monitor system conditions directly from the hardware setup.



Fig.5 LCD Real-Time Parameters

Fig. 5 shows the LCD displaying real-time electrical parameters, demonstrating the system's ability to provide continuous and accurate local monitoring of substation conditions.

D) IoT Cloud Output Results

The IoT cloud platform is used to display and analyze the monitored parameters in real time. The data transmitted from the microcontroller through the ESP8266 module is stored and visualized in the form of graphs. These graphical outputs help in understanding parameter variations and system behavior under different operating conditions.

Temperature Monitoring: The temperature monitoring graph shows continuous variation of temperature values recorded by the system. During testing, the minimum temperature recorded was 32°C, the maximum temperature reached 148°C, and the final observed value was 42°C. The graph indicates that temperature increases with load conditions and decreases when the load is reduced. This behavior confirms that the system effectively detects temperature changes and can identify overheating conditions.

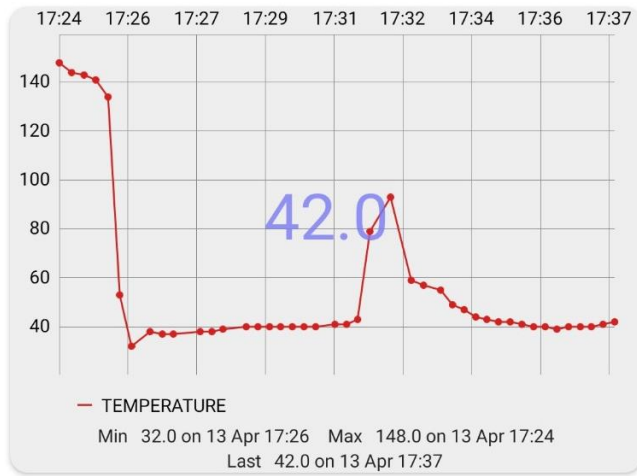

Fig.6 Temperature

Fig. 6 shows the IoT cloud temperature monitoring output, illustrating real-time updates and variation trends.

Frequency Monitoring: The frequency graph represents the stability of the power system. The minimum frequency recorded was 50.1 Hz, the maximum value was 50.41 Hz, and the final value was 50.26 Hz. The graph shows that the frequency remains close to the standard value of 50 Hz, indicating stable system operation. Minor fluctuations observed are within acceptable limits.

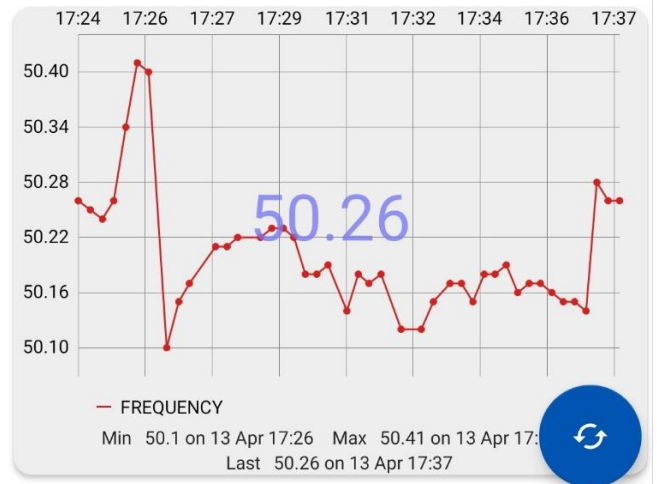

Fig.7 Frequency

Fig. 7 shows the IoT cloud frequency monitoring output, demonstrating consistent and stable frequency measurements.

Voltage Monitoring: The voltage monitoring graph displays variations in system voltage over time. The minimum voltage recorded was 214 V, the maximum voltage reached 292 V, and the final value was 229 V. The graph shows fluctuations due to varying load conditions, but the voltage remains close to the nominal value of 230 V for most of the time. This indicates effective monitoring of both overvoltage and undervoltage conditions.



Fig.8 Voltage

Fig. 8 shows the IoT cloud voltage monitoring output, highlighting voltage variation trends.

Power Monitoring: The power monitoring graph represents the real-time power consumption of the connected load. The minimum power recorded was 0 W, the maximum value was 93 W, and the final value was 88 W. The graph shows that power increases when the load is connected and decreases when the load is removed. This confirms that the system accurately tracks load-dependent power variations.

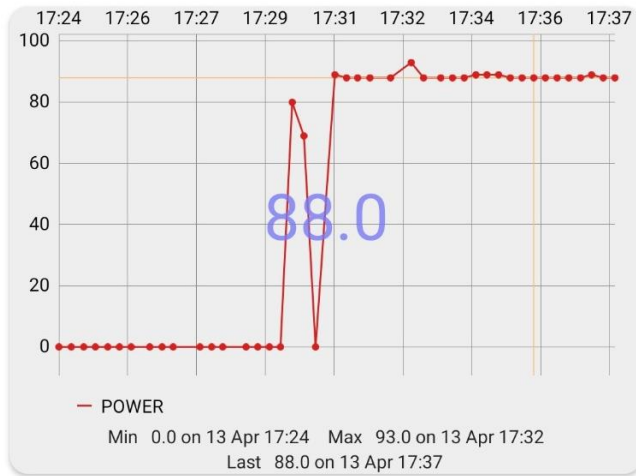

Fig.9 Power

Fig. 9 shows the IoT cloud power monitoring output, demonstrating real-time power monitoring capability.

E) Result Analysis Table

Table 1: Result Analysis of Monitored Parameters

Parameter	Minimum Value	Maximum Value	Final Value	Normal Range
Voltage	214 V	292 V	229 V	220–240 V
Frequency	50.1 Hz	50.41 Hz	50.26 Hz	Around 50 Hz
Temperature	32°C	148°C	42°C	Below 50°C
Power	0 W	93 W	88 W	Depends on Load

Table 1 summarizes the observed parameters obtained from the proposed IoT-based substation monitoring system. It presents the minimum, maximum, and final recorded values along with their respective normal operating ranges. The results indicate that the system is capable of accurately

measuring and monitoring all parameters in real time, while also detecting variations and abnormal conditions effectively.

F) Discussion of Results

The results obtained from the proposed IoT-based substation monitoring system demonstrate its effectiveness in real-time monitoring and analysis of electrical parameters. The system shows good accuracy in measuring voltage, temperature, frequency, and power, as the recorded values closely match the expected operating ranges. The use of sensors and microcontroller ensures reliable data acquisition with minimal deviation.

In terms of real-time performance, the system successfully transmits data continuously to the cloud platform without significant delay. The LCD display and IoT dashboard provide instant updates, allowing both local and remote monitoring simultaneously. This confirms that the system is capable of maintaining continuous and uninterrupted data flow.

The fault detection capability of the system is also effective. Abnormal conditions such as overvoltage, temperature rise, or sudden changes in power are clearly reflected in both the LCD display and cloud graphs. The presence of alert mechanisms such as buzzer and relay further enhances the system’s ability to respond quickly to unsafe conditions.

Additionally, the monitored parameters exhibit stable behavior under normal operating conditions. The frequency remains close to 50 Hz, and voltage values are mostly within the acceptable range, indicating system stability. Overall, the results confirm that the proposed system is reliable, efficient, and suitable for real-time substation monitoring applications.

V. CONCLUSION

The proposed IoT-based monitoring system for electrical substation parameters has been successfully designed, implemented, and tested to ensure reliable and efficient operation. The system effectively monitors key parameters such as voltage, temperature, frequency, and power in real time using sensors integrated with a microcontroller. The collected data is processed and transmitted to a cloud

platform through a Wi-Fi module, enabling remote monitoring through web and mobile interfaces. The inclusion of an LCD display also provides local visualization of system conditions. The experimental results demonstrate that the system provides accurate measurements and continuous data updates, allowing effective analysis of parameter variations. The system is capable of detecting abnormal conditions such as overvoltage, overheating, and load changes, thereby improving system safety and reducing the risk of equipment failure. Overall, the proposed solution enhances reliability, minimizes manual monitoring efforts, and offers an efficient approach for modern substation monitoring using IoT technology.

The proposed system can be further enhanced by integrating advanced technologies to improve its performance and scalability. The incorporation of artificial intelligence and machine learning techniques can enable predictive maintenance and early fault detection. The system can be extended to support automatic control and protection mechanisms for real-time response to faults. Additionally, the use of more accurate and industrial-grade sensors can improve measurement precision. Future developments may also include enhanced data security, mobile applications with advanced features, and integration with smart grid and renewable energy systems for large-scale deployment.

REFERENCES

- [1] Zhao, L., Matsuo, I. B. M., Zhou, Y., & Lee, W. J. (2019). Design of an industrial IoT-based monitoring system for power substations. *IEEE Transactions on Industry Applications*, 55(6), 5666–5674.
- [2] Ullah, Z., Rehman, A. U., Wang, S., Hasanien, H. M., Luo, P., Elkadeem, M. R., & Abido, M. A. (2023). IoT-based monitoring and control of substations and smart grids with renewables and electric vehicles integration. *Energy*, 282, 128924.
- [3] Hossain, M. S., Rahman, M., Sarker, M. T., Haque, M. E., & Jahid, A. (2019). A smart IoT based system for monitoring and controlling the sub-station equipment. *Internet of Things*, 7, 100085.
- [4] Ravi, R. V., Goyal, S. B., Constantin, N. B., Raboaca, M. S., Verma, C., & Kustov, V. (2022). Monitoring and control of electrical substation using IoT and cloud. *IEEE*.
- [5] Alam, M. T., Ashiquzzaman, M., Alam, S. M. T., Mostak, M. S., Rahman, H., & Das, P. (2023). IoT-Based Power Monitoring and Management System of a Distribution Substation. *IEEE ICPS*.
- [6] Talha, M. A., Rashed, R. R., Ahmad, S., Rofique, R., Bhuyan, M. H., Howlader, S., & Hassan, M. (2023). IoT-based real-time monitoring and control system for distribution substation. *IEEE ICPS*.
- [7] Ramtekkar, P. (2024). Remote Monitoring and Control of Electrical Substation. *IEEE ICSPE*.
- [8] Verma, A., Srivastava, D., Mishra, N., Sachdeva, N., Jha, S. K., & Verma, S. (2023). IoT-Based Substation Monitoring and Controlling. *Smart Grids for Smart Cities*, 199–223.
- [9] Sai Kiran, P., Venkateswara Rao, B., Satyamohan Sarveswar, G., & Manikanta, P. (2023). IoT-based monitoring and controlling of substation parameters. *Springer Conference*.
- [10] Mohammed, E. A., Al-Allaf, A. F., & Altamer, B. R. (2020). IoT-based monitoring and management power sub-station. *IOP Conference Series*.
- [11] Rehman, S. U., Mustafa, H., & Larik, A. R. (2021). IoT based substation monitoring & control system using Arduino with data logging. *IEEE ICCIS*.
- [12] Lakshmi, K. S., Ganesh, G., Jagadhis, K., Ram, G. S., & Krishna, K. V. (2022). IoT based substation monitoring and control. *IJRASET*.
- [13] Kalpana, S., Saranya, N., & Saundariya, K. (2021). An IoT Based Real-Time Monitoring and Controlling of Sub-Station Equipment. *IEEE ICSCAN*.
- [14] Sathish, R., & Ramraj, R. (2021). IoT Based Substation Monitoring and Control. *Journal of Tianjin University Science and Technology*.

- [15] Deore, C., Varade, V., Bhil, D., Patil, G., & Ahire, U. (2024). IoT-Powered Substation Surveillance System. International Journal.
- [16] Raghuvamsi, Y., Parri, S., Batchu, S., Abdul, I., & Parri, S. (2025). IoT Based Substation Equipment Monitoring System with CNN Integration. IEEE AIC.
- [17] Padmashini, R. K., Lakshmi, D., Rajasree, R., Rajesh Kumar, J. N., Zahira, R., Sivaraman, P., & Sharmeela, C. (2025). IoT-Based Monitoring for Substations. IoT for Smart Grid Book Chapter.