

# GSM Based Industry Protection System

KAJAL YADAV<sup>1</sup>, SAKSHI SAHANI<sup>2</sup>, SANJANA<sup>3</sup>  
<sup>1,2,3</sup>*Institute Of Technology and Management*

*Abstract- Industrial environments often involve hazardous conditions such as excessive heat, gas leakage, fire risks, and unauthorized access, which can lead to serious accidents and financial losses if not handled in time. This paper presents the design and implementation of a GSM-based industrial protection system that provides continuous monitoring and instant communication of critical events. The proposed system integrates multiple sensors, including temperature, gas, smoke, and motion detectors, with a microcontroller to observe environmental conditions in real time. When any parameter crosses a predefined safety threshold, the system automatically triggers protective actions such as activating alarms and shutting down machinery through a relay mechanism. Simultaneously, it sends alert messages to authorized personnel using GSM technology, ensuring rapid response even from remote locations. The use of GSM communication makes the system highly accessible, reliable, and independent of complex network infrastructure.[1]The system is designed to be cost-effective, easy to install, and scalable, making it suitable for a wide range of industrial applications, from small manufacturing units to large-scale plants. Overall, the proposed solution enhances industrial safety by minimizing human intervention, reducing response time, and preventing potential hazards before they escalate into major incidents.*

*Keywords-GSM Technology, Industrial Safety, Microcontroller, Sensors, Remote Monitoring, Automation, Hazard Detection, SMS Alert System.*

## I. INTRODUCTION

Industrial growth has significantly increased the use of complex machinery and hazardous materials, which has also raised serious concerns about safety and security within industrial environments. Accidents such as gas leaks, fire outbreaks, overheating of equipment, and unauthorized entry can lead to major losses, including damage to property and risk to human life. Therefore, ensuring continuous monitoring and quick response to such situations has become an essential requirement for modern industries.

Traditional safety systems mainly depend on manual supervision or basic alarm mechanisms. These methods are often limited because they cannot provide real-time updates to responsible personnel, especially when they are not physically present at the site[2].

As a result, delays in detecting and responding to critical situations may occur, increasing the chances of severe damage.

To overcome these limitations, communication technologies like GSM (Global System for Mobile Communication) can be effectively used. GSM technology allows information to be transmitted over long distances in the form of text messages, making it possible to alert users instantly, regardless of their location[1]. By combining GSM with embedded systems, industries can achieve a smarter and more reliable protection system[3].

In this work, a GSM-based industrial protection system is proposed, which integrates various sensors with a microcontroller to continuously monitor environmental conditions. The system is capable of detecting abnormal situations such as high temperature, gas leakage, and unauthorized motion. Once any unsafe condition is identified, the system not only activates local alarms but also sends an alert message to the concerned person through GSM. Additionally, it can automatically control industrial equipment using relay circuits to prevent further damage.

The proposed system is designed with a focus on simplicity, cost-effectiveness, and efficiency. It can be easily implemented in different types of industries and can be further enhanced with advanced technologies. Overall, this system provides a practical solution for improving industrial safety and reducing risks associated with delayed response.

## II. LITERATURE REVIEW

In recent years, researchers have shown significant interest in improving industrial safety using embedded systems and wireless communication technologies. Many studies have focused on developing automated systems that can detect hazardous conditions and notify users in real time.

Some earlier works introduced fire detection systems that rely on temperature and smoke sensors to identify abnormal conditions at an early stage. These systems were effective in minimizing fire-related risks but often lacked remote communication capabilities[2].

Later, GSM technology was incorporated into such systems to enable alert messages to be sent directly to users[3], making them more efficient and practical.

These systems proved useful in preventing accidents, but many of them were designed to monitor only a single parameter, limiting their overall effectiveness.

In addition, security-based systems using motion sensors have been developed to detect unauthorized access in restricted areas. While these systems enhance security, they do not always address environmental hazards like temperature rise or gas leakage.

More advanced systems have attempted to combine multiple sensors with microcontrollers to create integrated safety solutions. However, some of these designs are complex and expensive, making them less suitable for small-scale industries[6].

From the review of existing work, it can be observed that there is a need for a simple, cost-effective, and multi-functional system that can monitor different types of hazards simultaneously and provide instant alerts. The proposed GSM-based industrial protection system aims to address these gaps by combining multiple sensing units with reliable communication technology.

### III. PROBLEM STATEMENT

Industrial environments are becoming increasingly complex due to the use of advanced machinery, high-temperature processes, and hazardous materials such as flammable gases and chemicals. While these advancements improve productivity, they also introduce serious safety challenges. Accidents such as gas leakage, fire outbreaks, overheating of equipment, and unauthorized access can occur at any time and may lead to severe consequences, including damage to infrastructure, financial losses, and risks to human life.

In many industries, safety still depends largely on manual monitoring or basic alarm systems. These traditional approaches have several limitations. Human supervision is not always continuous or reliable, especially in large industrial setups where it is difficult to monitor all areas at once[2]. In critical situations, even a small delay in detecting a hazard can cause the problem to escalate rapidly. Basic alarm systems, although helpful, are often limited to local alerts and do not provide remote notification to responsible personnel.

Another major issue is the lack of integration between different safety parameters. Many existing systems are designed to monitor only one condition, such as temperature or gas leakage, rather than providing a combined solution[3]. This makes them less effective in real-world industrial environments, where multiple types of hazards can occur simultaneously.

Furthermore, the absence of real-time communication systems creates a gap between the occurrence of a problem and the response from the concerned authorities. If an abnormal condition arises when no personnel are present on-site, the delay in response can lead to serious damage. Industries require a system that can not only detect hazards instantly but also communicate this information to users regardless of their location.

Therefore, there is a strong need for an automated, reliable, and cost-effective industrial protection system that can continuously monitor multiple environmental conditions, detect abnormalities in real time, and provide immediate alerts through a remote

communication mechanism[6]. The system should also be capable of taking preventive actions, such as shutting down machinery, to minimize risks and prevent further damage.

The proposed GSM-based industrial protection system is designed to address these challenges by combining sensor-based monitoring with wireless communication technology, ensuring faster response, improved safety, and reduced dependency on manual supervision.

#### IV. OBJECTIVE

The main goal of this research is to design a reliable and efficient system that can improve safety in industrial environments by using modern communication and monitoring technologies. The objectives of the proposed GSM-based industrial protection system are described below.

The first objective is to develop an automated system that can continuously monitor different environmental conditions without the need for constant human supervision. In industrial settings, it is not always practical for personnel to observe every parameter manually, especially in large or hazardous areas. Therefore, automation plays a key role in ensuring consistent and accurate monitoring.

Another important objective is to detect various types of hazards such as high temperature, gas leakage, fire, and unauthorized movement. These are some of the most common risks found in industries, and early detection is essential to prevent them from turning into major incidents. By using multiple sensors, the system aims to provide a more complete and reliable safety solution.

The system also aims to provide real-time communication using GSM technology. Whenever an abnormal condition is detected, the system should immediately send an alert message to authorized personnel. This ensures that even if no one is present at the site, the concerned person can be informed quickly and take appropriate action[6].

In addition to detection and communication, another objective is to implement automatic control

mechanisms. The system should be capable of taking preventive actions, such as turning off machines or activating alarms, to reduce the impact of hazardous situations. This helps in minimizing damage and improving overall safety.

#### V. SYSTEM ARCHITECTURE

Block diagram-

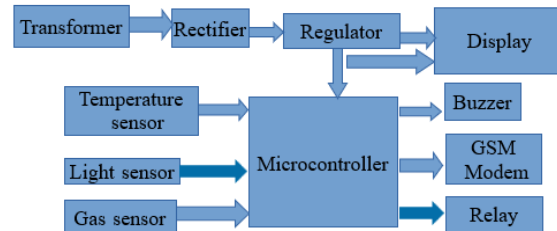

Figure 1. Block Diagram

Transformer-A transformer is an electrical device used to change the voltage level of alternating current (AC) without changing its frequency. In simple terms, it either increases (step-up) or decreases (step-down) the voltage according to the requirement of the system.

the transformer plays a very important role in the power supply section. The main purpose of using a transformer is to convert high voltage into a safe and usable low voltage for electronic components[9].

In homes and industries, the available power supply is 230V AC, which is very high and dangerous for electronic components like:

- Arduino/Microcontroller
- GSM Modem
- Sensor

These components usually work on 5V or 12V DC, not on high AC voltage.

So, we need a transformer to reduce this voltage.

Rectifier-The rectifier is an essential part of the power supply section. Its main role is to convert alternating current (AC) into direct current (DC) so that electronic components can work properly[9].

After using a transformer, the voltage is reduced from 230V AC to low voltage AC (like 12V AC).

However, this is still AC, which continuously changes direction.

But components such as:

- Arduino/Microcontroller
- GSM Modem
- Sensor

All require DC (direct current), which flows in only one direction.

So, AC cannot be used directly — it must be converted into DC.

Regulator-The voltage regulator is used to provide a stable and constant DC voltage to all electronic components. It is a crucial part of the power supply section because even after converting AC to DC, the voltage is not perfectly stable[9].

After the rectifier and filter stages:

- The output is DC, but it is not steady.
- There may be small fluctuations or ripples.
- Voltage may increase or decrease slightly.

However, components like:

- Arduino/Microcontroller
- GSM Modem
- Sensor

require a fixed voltage (like 5V or 12V) to work properly.

Even a small variation can cause:

- Improper functioning
- System error
- Damage to components

So, a regulator is needed to maintain a constant voltage.

Temperature sensor-The temperature sensor is used to monitor heat levels continuously and detect any abnormal rise in temperature. It plays an important role in preventing accidents related to overheating and fire hazards[10].

In industrial environments, machines and electrical equipment often generate heat during operation. Under normal conditions, this heat remains within a safe limit. However, due to issues like:

- Overloading of machine
- Short circuits

- Poor ventilation
- Continuous operation

The temperature sensor continuously measures the surrounding or machine temperature and sends this data to the microcontroller.

Step-by-step:

- Sensor detect temperature
- Converts it into electrical signal
- Send signal to microcontroller
- Microcontroller compares with set limit
- If temperature is too high:
- Alarm is activated
- Machine is turned off
- GSM alert is sent

Gas sensor-In many industries, different types of gases are used or produced during processes. Sometimes, due to leakage, equipment failure, or poor maintenance, these gases can spread into the surrounding area.

The gas sensor continuously senses the air around it and detects the presence of gases[3].

Step-by-step:

- Gas sensor detect gas in the environment
- It converts gas concentration into an electrical signal
- Signal is sent to the microcontroller
- Microcontroller is compares it with a set limit
- If gas level is high:
- Alarm is activated
- Machine is turned off
- SMS alert is sent through GSM

Light sensor-The light sensor is used to monitor the intensity of light in the surrounding environment. It helps in detecting abnormal lighting conditions, which can indicate issues such as power failure, unauthorized activity, or unsafe working conditions.

In industrial areas, proper lighting is very important for safe and smooth operation. Sudden changes in light intensity can occur due to:

- Power is failure
- Fault in electrical system
- Unauthorized access (light turned on/off)
- Fire or smoke effecting visibility

Such changes may create unsafe conditions for workers and can also indicate that something is wrong in the system. If these changes are not detected in time, they may lead to accidents or security risks.

The light sensor continuously measures the level of light in the environment and sends this information to the microcontroller.

**Arduino/Microcontroller**-The Arduino acts as a central control unit that manages and coordinates the entire system. It is responsible for receiving data from sensors, processing that data, and taking appropriate actions based on predefined conditions.

The Arduino continuously monitors inputs from all connected sensors and processes them in real time[4].

Step-by-step:

- Sensor send the data to the microcontroller
- Microcontroller reads and processes the data
- It compares values with present thresholds
- If any abnormal condition is detected:
- Activates alarm (buzzer)
- Turn OFF machinery using relay
- Sends alert via GSM Module
- If conditions are normal, system continues monitoring

**GSM Modem**-The GSM modem is used to establish communication between the system and the mobile network[1]. It allows the system to send important information and alerts to the user in real time, especially during emergency condition.

In an industrial setup, continuous monitoring is required, but it is not practical for a person to always stay near the system. When any abnormal situation occurs, such as:

- Increase in temperature
- Gas leakage
- Fire risk
- System failure

it becomes very important to inform the concerned person immediately, even if they are far away.

The GSM modem solves this problem by enabling long-distance wireless communication using the mobile network.

The GSM modem works as a bridge between the microcontroller and the cellular network. It uses a SIM card to send and receive messages.

**Relay**-The relay is used to control high-power electrical devices using low-power signals from the microcontroller. It acts as a switching device that helps in turning ON or OFF industrial equipment automatically during unsafe conditions.

The microcontroller works on low voltage (like 5V) and cannot directly control heavy machines or high-voltage devices. However, in industries, machines operate on high voltage and current.

So, a relay is required to:

- Act as an interface between low power and high power circuits.
- Allow safe control of electrical devices.
- Enable automatic shutdown during emergencies.

**Buzzer**-The buzzer is used to provide an immediate audible alert when any abnormal condition is detected. It helps in warning nearby workers instantly.

While GSM sends alerts remotely, people working near the system also need to be warned immediately.

Situations like:

- Gas leakage
- High temperature
- Fire risk

**Display**-The display unit (such as an LCD) is used to show real-time information about the system status and sensor readings. It provides a simple and direct way for users to monitor what is happening inside the system.

Although the system sends alerts through GSM and gives sound warnings using a buzzer, there is still a need for a visual interface. The display helps users understand the system condition instantly without needing a mobile phone or external device.

Circuit diagram-

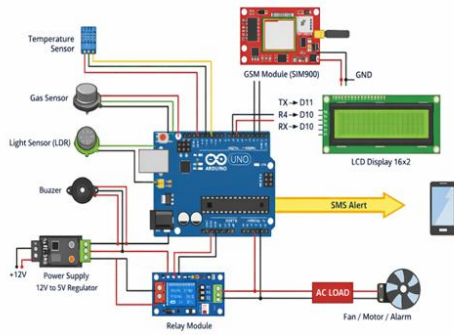

Figure 2. Circuit Diagram

## VI. ADVANTAGES

- Real-Time monitoring and alert-The system continuously checks industrial conditions and instantly sends alerts when any abnormal situation occurs, ensuring quick awareness[6].
- Reduce human Alert-Automation eliminates the need for constant manual supervision, making the system more efficient and less prone to human error[6].
- Improved safety-Early detection of hazards like gas leakage, overheating, or fire helps in preventing serious accidents and protecting both workers and equipment[3].
- Remote Accessibility-With GSM communication, alerts can be received on mobile phones from any location, allowing users to stay informed even when they are not on-site[1].
- Fast response Time-The system reacts immediately to dangerous conditions and sends notifications without delay, enabling quick action.
- Scalability and flexibility-Additional sensors or modules can be added easily, allowing the system to grow according to industrial needs.
- Automatic control action-The system can automatically activate alarms or control devices (like turning off machines), reducing the impact of hazards.
- Easy installation and maintenance-The design is simple and modular, making it easy to install, troubleshoot, and maintain.
- Reliable Communication-GSM technology ensures dependable message delivery, even in remote areas with basic network coverage.

- Cost-effective solution- It is built using affordable and easily available components, making it suitable for small and medium industries.

## VII. LIMITATION

- Dependence on network Availability-The system relies on GSM communication to send alerts. If the network signal is weak or unavailable, messages may be delayed or not delivered at all, which can affect timely response.
- Limited range of sensor-The effectiveness of the system depends on the types and number of sensors used. If a hazard is not covered by the installed sensors, it may go undetected.
- Power supply Dependency- Continuous operation requires a stable power supply. In case of power failure, the system may stop working unless a backup source is provided.
- Maintenance requirement- Sensors and electronic components need regular checking and maintenance to ensure accurate performance over time.
- Security concern-GSM communication is not highly secure, so there is a possibility of unauthorized access or interception of alert messages.

## VIII. APPLICATION

- Industrial safety monitoring- The system is widely used in industries to monitor critical parameters such as temperature and gas levels. It helps in maintaining a safe working environment by detecting hazards at an early stage.
- Fire Detection and prevention- By sensing abnormal temperature rise or gas leakage, the system can act as an early warning mechanism to prevent fire accidents in factories and storage units.
- Power Plants and Electrical Units- The system can be used to monitor equipment temperature and prevent overheating, which helps in avoiding failures and improving system reliability.
- Remote Industrial Areas-

In locations where human supervision is limited, the system provides remote monitoring through GSM, ensuring that important updates are still received.

- Small-Scale industries and workshop-  
Due to its low cost and simple design, the system is ideal for small industries where advanced safety systems are not affordable.

#### IX. FUTURE SCOPE

- Integration with IoT Technology-  
The system can be enhanced by connecting it to the internet, allowing users to monitor and control industrial conditions through mobile apps or web dashboards.
- Cloud data storage and Analysis-  
Future versions can store sensor data on cloud platforms, enabling long-term analysis and better decision-making.
- Advanced sensor integration-  
More precise and diverse sensors can be added to detect additional parameters such as humidity, smoke, pressure, and vibration.
- Improved security features-  
Encryption and secure communication methods can be added to protect data and prevent unauthorized access.
- Wireless sensor networks-  
Multiple sensors can be connected wirelessly over a large industrial area to improve coverage and flexibility.
- Energy efficient design-  
The system can be optimized for lower power consumption, making it suitable for continuous operation and remote locations.
- Scalability for Large Industries -  
Future improvements can make the system suitable for large-scale industries with centralized monitoring and control.

#### X. CONCLUSION

The GSM-based industrial protection system presents an effective and reliable solution for enhancing safety in industrial environments. By continuously monitoring important parameters such as temperature, gas levels, and light intensity, the

system is able to detect abnormal conditions at an early stage and respond quickly.

The integration of a microcontroller with various sensors enables automatic decision-making, while the GSM communication ensures that alerts are delivered to the user in real time. This combination of monitoring, control, and communication helps in reducing risks, preventing accidents, and minimizing damage to equipment[6].

One of the key strengths of the system is its simplicity and cost-effectiveness, making it suitable for both small- and large-scale industries. It reduces the need for constant human supervision and improves overall operational efficiency. Although there are some limitations, such as dependence on network availability and sensor accuracy, the system can be further improved with advanced technologies in the future. Overall, the proposed system provides a practical and scalable approach to industrial safety and protection.

#### REFERENCES

- [1] T. S. Rappaport, *Wireless Communications: Principles and Practice*, 2nd ed. New Delhi, India: Pearson Education, 2002.
- [2] S. Rajalakshmi and M. Devi, "Industrial Safety Monitoring System Using GSM," *International Journal of Engineering Research & Technology (IJERT)*, vol. 4, no. 3, pp. 123–126, 2015.
- [3] A. Kumar and R. Singh, "Gas Leakage Detection and Alert System Using GSM," *International Journal of Advanced Research in Electrical, Electronics and Instrumentation Engineering*, vol. 5, no. 6, pp. 4567–4572, 2016.
- [4] M. Banzi and M. Shiloh, *Getting Started with Arduino*, 3rd ed. USA: Maker Media, 2015.
- [5] N. Sriskanthan and F. Tan, "Wireless Sensor Networks for Industrial Applications," *IEEE Potentials*, vol. 23, no. 4, pp. 12–16, 2004.
- [6] D. Patil and S. Patil, "Arduino Based Smart Safety System," *International Journal of Innovative Research in Science, Engineering and Technology*, vol. 6, no. 5, pp. 7890–7895, 2017.

- [7] K. Ogata, Modern Control Engineering, 5th ed. New Delhi, India: Prentice Hall, 2010.
- [8] GSM Association, “Introduction to GSM Technology,” Available: <https://www.gsma.com>
- [9] A. K. Sawhney, Electrical and Electronic Measurements and Instrumentation. New Delhi, India: Dhanpat Rai & Co., 2012.
- [10] J. Fraden, Handbook of Modern Sensors: Physics, Designs, and Applications, 4th ed. New York, USA: Springer, 2010.